

15CL100 (COLOR MODEL)

COLOR TV RECEIVER MODEL 15CL100 FIRST & SECOND PRODUCTION

The General Electric model 15CL100 is a twelve channel console color television receiver. Some 15CL100 receivers have been factory equipped with a UHF tuner unit which provides additional coverage from channel No. 14 through No. 83 by means of double conversion.

This instrument will reproduce monochrome or color programs and automatically shift its function from one to the other by means of an incorporated "color killer" circuit.

The model 15CL100 incorporates 36 tubes, 4 high voltage rectifiers, 2 selenium power rectifiers, 2 crystal diodes and a 3.58 mc piezo-electric crystal. Receivers incorporating UHF contain 2 more tubes and one additional crystal diode.

Among the features to be found in this receiver are keyed AGC, highly stabilized horizontal AFC, horizontal and vertical retrace blanking, an automatic "color killer", DC restoration, a three tube high efficiency high voltage doubler and a high voltage regulator tube and circuit. This receiver utilizes an aluminized planar type tricolor picture tube.

The following data includes installation instructions, preliminary service data including the required schematic diagrams, a receiver analysis based upon an accompanying block diagrams and a preliminary parts list containing the most essential items required for service.

Second production receivers differ somewhat from first production receivers insofar as the schematic diagram and component layout are concerned.

SPECIFICATIONS

POWER INPUT RATING:

Frequency - 60 cycles.
Voltage - 115 volts.
Wattage - 425 watts.

RF FREQUENCY RANGE (VHF):

Channels - No. 2 through No. 13.
Frequencies - 54-88 mc, 174-216 mc.

RECEIVERS EQUIPPED WITH UHF:

Channels - 14 thru 83,470-890 mc

This coverage is in addition to above noted UHF channels.

OPERATIONAL FREQUENCIES:

Picture IF carrier - 45.75 mc.
Adjacent channel audio trap - 47.25 mc.
Adjacent channel video trap - 38.00 mc.
Sound IF carrier - 41.25 mc.
Intercarrier sound take-off - 4.50 mc.
Chrominance IF carrier - 42.17 mc.
Chrominance signal take-off - 3.58 mc.

AUDIO POWER OUTPUT:

Undistorted - 2.5 watts.
Maximum - 5.0 watts.

LOUDSPEAKER:

Type - Alnico PM.
Cone Diameter - 10 inches.
Impedance at 400 cycles - 3.2 ohms.

PICTURE TUBE:

Type - 15GP22. Size-15 inches, round.
Deflection - electro-magnetic
Deflection angle - 45 degrees
Focus - electro-static.

DANGER

The high voltages generated in these receivers are capable of delivering A LETHAL SHOCK! Extreme care should be exercised to avoid contact with high-voltage carrying leads or the final anode of the picture tube while the receiver is in operation. Under no conditions should makeshift picture tube connections be made which will defeat the purpose of the receiver's protective insulating devices thereby subjecting service personnel to dangerous shock hazard.

Also note: Mild x-rays are emitted by the Z-2188 high voltage regulator. Because of this and the dangerous shock hazard, never operate the receiver with the high-voltage compartment cover removed.

The picture tube is highly evacuated and if broken, glass fragments will be violently expelled. When handling the picture tube always wear goggles.

GENERAL

The following procedure concerns the adjustment of those items which may, upon arrival of the receiver, require re-adjustment due to transportation handling etc. Fundamentally, these controls are adjusted in such a manner as to provide good monochrome picture reproduction. Once these controls have been adjusted for good monochrome reception, good color reproduction will be had, provided that the internal (top of chassis) adjustments have not been tampered with.

The following data describes the functions of the various controls and is tabulated in a sequence which should be followed in the event that a complete set-up procedure is required. Refer to figures 1, 2 and 3. The following adjustments should be made after the room has been darkened.

INSTALLATION

The receiver is shipped with the tri-color picture tube installed and with all controls pre-adjusted for normal operation. If upon installation of the receiver, it is determined that certain control or picture tube adjustments are necessary, refer to the following procedures. The required adjustments are somewhat more complex than those previously encountered on monochrome receivers. Hence, only qualified technical service personnel should attempt these adjustments.

EXTERNAL ANTENNA SYSTEMS

In general, existing monochrome antenna systems may be found satisfactory for good color program reception. It should be borne in mind however, that it is possible for a poorly installed or adjusted antenna system to provide poor color reception - particularly those systems which display a sharp frequency cut-off characteristic within the frequency limits of a locally active television channel. In all cases, the antenna system should be favorably located and checked for proper orientation and termination.

EQUIPMENT REQUIRED

The only piece of equipment necessary to perform the installation adjustments, aside from the usual installation tools, is a dot generator. The dot generator should supply "white" dots (negative video modulation of a VHF channel carrier). The diameter of the dots should not exceed the approximate width of 2 or 3 scanning lines. Other dot generators also may be used which supply white "squares" or "rectangles", the edges of which are sharp or well defined.

Do not attempt the following procedure with dot generators of the "black dot" variety.

COLOR PURITY

These adjustments are required to assure that the electron beams of each picture tube gun will strike only their respective color phosphor dots throughout the entire screen area.

1. Set following controls fully counter-clockwise: picture contrast, chroma, brightness, blue and green G1 controls, green and blue gain controls, red, green and blue G2 controls, purity, DC convergence and field neutralizing control.
2. Apply power to receiver, antenna need not be connected.
3. Advance red G2 control and brightness control until screen is illuminated.
4. Loosen securing screw in neck shield assembly and rotate assembly so that blue beam positioning magnet lies directly over blue (top) gun in picture tube. Unscrew all three beam positioning magnets just short of the point at which they fall out of assembly.

5. Put on a pair of high quality high-voltage insulating gloves to prevent possible shock from yoke wiring. Loosen top and bottom yoke adjustment wing screws and slide yoke back and forth to obtain purest red field in center of raster. Tighten wing screws.

6. Adjust purity control (front chassis apron) for purest red field in center of raster. Simultaneously rotates purity coil (independently of neck shield) for purest red field in center of raster.

7. Adjust field neutralizing control (front panel) for uniform red field at edges of the raster.

8. If the entire raster is not pure red, loosen the top and bottom yoke adjustment wing screws and slightly tilt the yoke either forward or backward as required. Do not attempt to tilt yoke from side to side.

9. Check purity on blue and green fields separately. This is done by rotating the red G2 control fully counter-clockwise and turning up either the green or blue G2 control to produce a green or blue raster. When so doing, the red, green and blue fields should each be pure to within 1/4 inch from the raster edges.

RASTER ADJUSTMENTS

These adjustments are performed to shape and frame the picture in a manner similar to monochrome practice.

1. Connect antenna and tune receiver to suitable test pattern. Leave the blue and green G1 controls fully counter-clockwise, but set the red, green and blue G2 controls at approximately mid-position.
2. Adjust the brightness and contrast controls for normal picture. (Disregard any color effects in the raster).
3. Adjust the horizontal drive control just below the point at which a bright vertical line appears on the raster.
4. Adjust the vertical size and linearity and the width and horizontal linearity controls for a linear raster which extends beyond the mask limits approximately 1/8 inch on all edges.

BEAM POSITIONING MAGNETS

This adjustment is required to axially orient the individual electron guns in the picture tube so that they may be made to converge in the center of the screen.

1. Turn receiver off. Turn brightness control fully counter-clockwise. Connect "white" dot or generator signal into antenna terminals of receiver. Make the necessary contrast and brightness control adjustments. With all three (red,

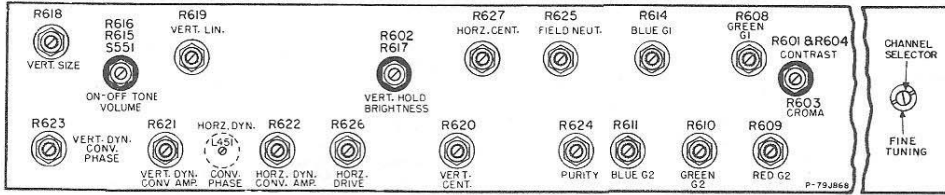

FIG. 1. FRONT PANEL ADJUSTMENTS

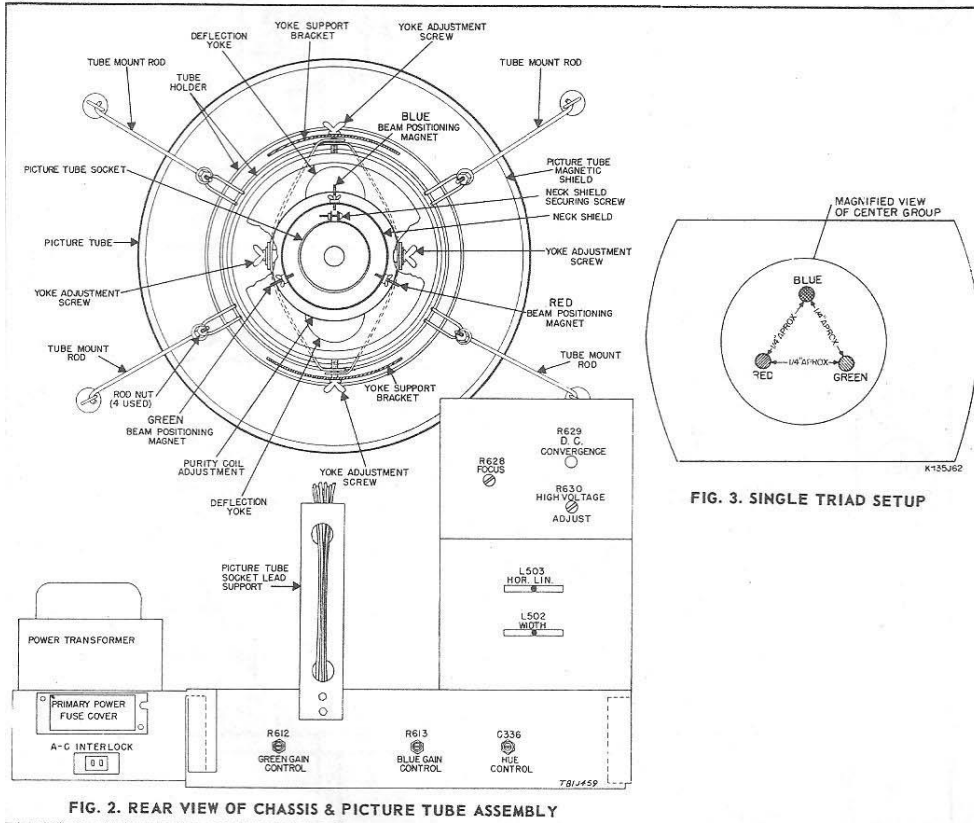

FIG. 2. REAR VIEW OF CHASSIS & PICTURE TUBE ASSEMBLY

green, and blue G2) controls turned up about half way set the brightness control to provide for low brightness dots. Turn the DC (static) convergence control located on the rear of the receiver counter-clockwise just enough so that the beams under-converge and hence form many groups of three separate dots each; that is, one red, one green and one blue dot in each group. Set the G2 controls for equal brightness of the dots and the brightness control for just sufficient visibility to permit adjustment.

2. The DC convergence control should be adjusted so that a displacement of approximately $\frac{1}{4}$ " exists between dot centers. Focus the dots with the focus control.

3. Starting with the three beam positioning magnets in their maximum outward position, screw each of them in, a little at a time, and note their effect upon the dot structure in one of the dot groups in the center of the raster. These magnets should each be screwed in just enough to form an equilateral triangle of dots in any center raster group or triad as shown in figure 3. If this cannot easily be achieved, the entire neck shield assembly may be rotated ± 15 degrees either side of the position at which the magnets lie directly over their respective guns. Do not rotate any more than 15 degrees in either direction. NOTE: The magnets should not be screwed in toward the tube guns any closer than absolutely necessary, since their magnetic influence tends to defocus the electron beams.

4. Adjust the DC convergence control until the three colored dots of the center - raster groups superimpose. Refocus the dots as the DC convergence control is adjusted. The end result should be one white dot instead of colored groups in the center of the screen. Disregard the fact, at this time, that the dot groups at the outer extremities of the raster are not properly converged.

DYNAMIC CONVERGENCE

These adjustments are necessary to create a perfectly converge condition throughout the entire screen area. These adjustments control the amplitude and phase or position of the dynamic convergence modulating voltages - both vertically and horizontally. This procedure also requires the use of a generator which supplies moderately small dots.

1. With the above noted dot generator signal fed into the receiver, proceed with the adjustments following. Adjust the contrast, brightness, and/or individual G2 controls so that all three colors in the pattern are visible at the raster edges.

2. If DC convergence is set correctly center - raster dots will be converged. Now proceed to converge the dots throughout raster area. The horizontal phasing control L451 should be adjusted so that the two end points or triads along the center horizontal line converge at the same time when the DC convergence control R629 is rotated.

3. Adjust the horizontal dynamic convergence amplitude control R622 so that all points along the horizontal axis equally misconverge. Readjust the DC convergence control R629, so that the horizontal lines converge throughout their entirety. If proper amplitude and phasing has been accomplished, all points along the horizontal axis will converge at the same setting of the DC convergence control.

4. With the vertical dynamic convergence amplitude control turned up about half way, adjust the vertical dynamic convergence phasing control R623 so that all points from the center of the raster on the vertical axis converge simultaneously when the DC convergence control R629 is varied.

5. Adjust the vertical dynamic convergence amplitude until all points along the vertical axis are equally misconverged.

NOTE: The vertical amplitude and vertical phasing controls are interacting and some readjustment of the phasing control may be required when the amplitude is varied.

6. Converge the dots vertically with the DC convergence control.

NOTE: The vertical and horizontal convergence adjustments are interacting. After Step 4 above has been completed. It may be necessary to readjust the horizontal amplitude control, R622.

GREY SCALE ADJUSTMENTS

These adjustments are required to produce an untinted (white) raster and picture throughout the useful brightness and contrast range.

1. Blue and green gain controls (on rear of chassis) should be set fully counter-clock-wise.

2. Tune in a monochrome test pattern then set the contrast control fully counter-clock-wise.

3. Turn the brightness control fully clockwise.

4. Adjust the red, green, and blue G2 controls for a very low brightness untinted grey raster.

5. Turn up the contrast control for a normal picture.

6. Adjust the blue and green gain controls, (rear of chassis) to produce white picture highlights.

7. Adjust the brightness control for a low brightness picture.

8. Adjust the blue and green G1 controls for a grey untinted picture.

9. Check to see that untinted (only white or grey) highlights may be had throughout the useful range of the contrast and brightness controls.

RECEIVER GENERAL DESCRIPTION

The color television receiver contains many circuits which are similar to those used in contemporary monochrome receivers. Additionally, the color receiver employs other circuitry necessary to decipher and reconstruct the original color information and to reproduce this information in terms of the Red, Green & Blue additive colorimetry on the face of a tri-color picture tube.

The receiver is shown in block form in figure 5. The RF amplifiers, converter and oscillator are all contained in a sub-assembly unit which bears great similarity to the RF tuner unit of present General Electric monochrome receivers. This unit, however, essentially differs from the monochrome unit in so far as the bandwidth and "tilt" limits are far more stringent than in monochrome practice since the higher frequency color sidebands must be preserved.

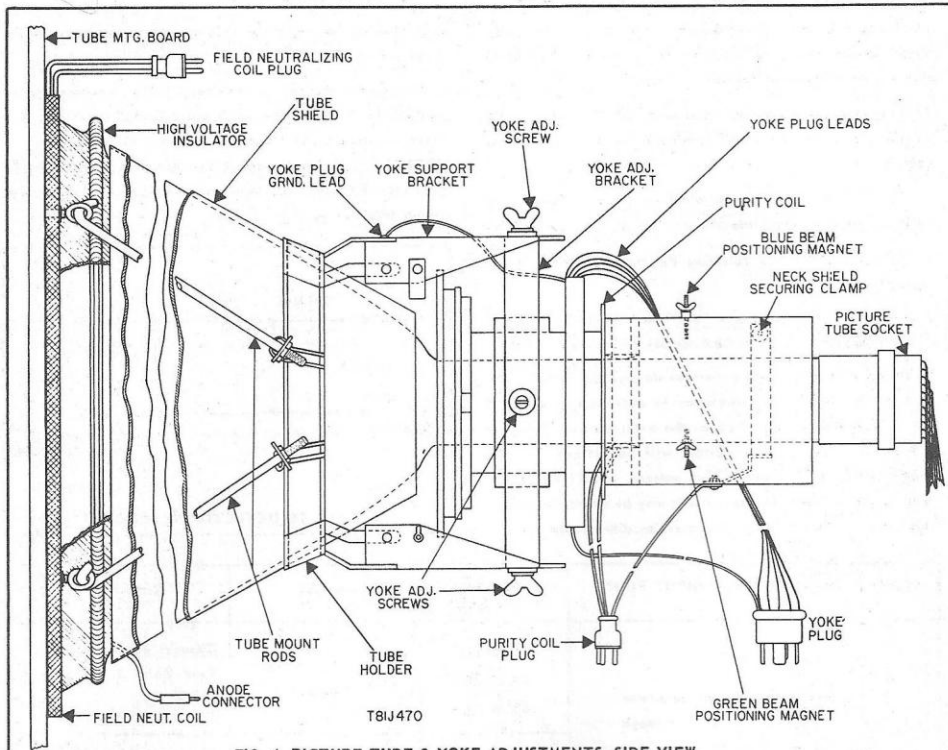

FIG. 4. PICTURE TUBE & YOKE ADJUSTMENTS, SIDE VIEW

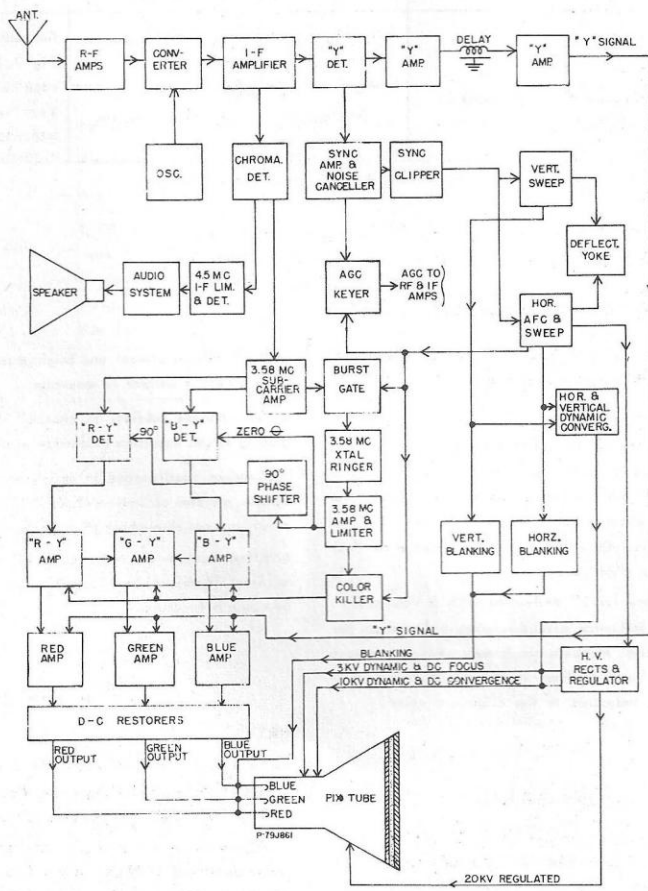

FIG. 5. BLOCK DIAGRAM OF COLOR TELEVISION RECEIVER

The output of the converter is link coupled into the IF system which employs four stages of amplification. The gain of the RF tuner and the IF system is controlled by AGC voltage derived from a conventional AGC keyer tube. The output of the IF system feeds two separate detector circuits.

One detector is designated as the "Y" detector, the output of which consists of the usual monochrome video and sync information. The other is the chrominance detector which delivers two output signals. One signal is the conventional 4.5 mc intercarrier sound IF signal which is then passed to a 4.5 megacycle amplifier, limiter, ratio detector and audio amplifiers in the usual manner. The other signal is the chrominance sub-carrier signal which is centered about the frequency of 3.58 megacycles. The signal output of this channel is split off in two directions. One signal is fed to the input of the two synchronous color detectors. The other chrominance signal is fed to a device called the burst gate. This stage is normally biased off and is driven into conduction by a pulse during the horizontal retrace interval. Thus, the burst gate will only pass the eight cycles of 3.58 mc "pilot" burst signal.

The 3.58 mc burst is then used to shock excite a 3.58 mc piezo-electric crystal, which in turn develops a continuous-wave 3.58 mc output voltage. This signal is next passed to a limiter, the output of which consists of two 90 degree out-of-phase voltages. One of these voltages fed to the B-Y synchronous detector and the other to the R-Y synchronous detector. By introducing these two out-of-phase voltages, we are, in effect, reinserting the 3.58 mc reference carrier, which of necessity, had been suppressed at the transmitter.

The output of the B-Y and R-Y detectors now consists of the "I" and "Q" color signals initially derived from the matrix amplifier at the transmitter, but both shifted 33 degrees in phase to produce instead, a "B-Y" and an "R-Y" color signal. The R-Y and B-Y signals are fed to their respective amplifiers.

The output voltages of these amplifiers are again divided into two separate signal paths. First, sample output voltages from both amplifiers are mixed in a simple adder to form a "G-Y" signal which is then amplified by the "G-Y" amplifier. Secondly, the output signals of the R-Y and B-Y amplifiers are fed to their respective Red, Green and Blue adders.

Before R-Y, G-Y and B-Y actually become R, G, and B, we must first add "Y" to each signal. As mentioned previously, the "Y" detector output contains all the monochrome detail information, which next is amplified by the "Y" amplifiers. Because the bandwidth of the 3.58 mc sub-carrier amplifier is made relatively narrow compared to the "Y" channel the color signals are somewhat delayed. Hence, the "Y" signals also must be accordingly delayed. A "lumped constant" delay line is inserted immediately ahead of the second "Y" amplifier to accomplish this end.

The "Y" signal is then added to the R-Y, G-Y and B-Y signals by means of simple resistive adders. The resulting R, G and B signals are amplified and then used to drive the R, G and B guns in the tri-color picture tube. DC restoration is incorporated in each gun circuit so that the black level reference will be maintained. If this facility were not incorporated, the picture background, on actually dark scenes, would not recede toward black but rather would assume some color other than that desired.

Since color television receivers will be called upon to also reproduce monochrome television programs, a means must be provided (preferably automatically) to disable the color circuits. It is generally true that in the absence of 3.58 mc side-bands, the R-Y and B-Y detectors will not function.

15CL100 (COLOR MODEL)

We should note however, that transmissions of a monochrome transmitter may include 3.58 mc side-band components which together with random noise may cause the synchronous detectors and the B-Y and R-Y amplifiers to function. This produces a spurious pattern called "parc", in the high detail portions of the picture, such as in the vertical wedge of a test pattern. A color killer circuit is incorporated so that in the absence of a 3.58 mc color transmission burst, the R-Y and B-Y amplifiers will be biased below condition and thus prevent the aforementioned objectionable color interference in the received monochrome picture.

The remainder of the receiver consists of those circuits required to generate and synchronize the various sweep waveforms, as well as to generate special dynamic convergence and focus waveforms required by the tri-color picture tube.

A sample of the detected "Y" signal is fed to the sync amplifier, noise canceller and clipper in the usual manner. The clipper supplies the vertical oscillator and horizontal phase detector with their respective synchronizing information.

The vertical oscillator and amplifier supply the required vertical sweep to the vertical deflection coils of the yoke. A portion of the vertical sweep waveform is picked off, shaped and then fed to a cathode follower. This blanking pulse is then impressed upon the cathode of each picture tube gun (R, G and B) to provide picture tube blanking during the vertical retrace interval. A parabolic waveform is also derived from the vertical output stage which is applied to a horizontal and vertical convergence tube. The dynamic convergence voltage developed by this tube is applied to the convergence electrode of the picture tube.

The horizontal phase detector functions in a manner similar to monochrome practice. It produces an automatic correcting voltage by virtue of a comparison between the phase and/or frequency of the incoming horizontal sync pulses and the pulses generated in the horizontal sweep system. The developed correction voltage is applied to a reactance tube which, in turn, controls the frequency of the horizontal oscillator. The horizontal discharge tube shapes the driving pulse which is applied to the horizontal output stage. This stage is coupled through the horizontal output transformer to the horizontal deflection coils of the sweep yoke assembly. As in monochrome practice, a diode damper is incorporated to dampen the undesired oscillations at the beginning of each horizontal sweep pulse and to use this energy, after rectification, to supply a boosted B plus supply voltage to the horizontal output stage and the vertical multivibrator.

Two high-voltage rectifiers systems are connected to the horizontal output transformer. The first rectifier to be considered is the 20,000 volt high efficiency doubler type rectifier which supplies the final anode of the picture tube. A special regulator tube is incorporated in this circuit to automatically regulate the final anode voltage so that it will not vary with changes in the luminosity of the picture.

The second high-voltage rectifier develops a potential of approximately 3000 volts and is applied through a potentiometer to the focusing electrodes of the picture tube guns.

A sample of the horizontal output transformer pulse is fed to the horizontal blanking tube, the output of which is connected to the picture tube cathodes to provide blanking during the horizontal retrace interval.

A parabolic waveform is derived from the horizontal output stage which is also applied to the horizontal and vertical convergence tube. This provides a dynamic horizontal convergence voltage which is applied to the picture tube convergence electrode.

The "composite" parabolic dynamic voltages are also used to modulate the 3000 volt focusing DC voltages. This is required to maintain good focus throughout the entire raster area.

The low voltage power supply is quite conventional in its design. It primary consists of a full wave voltage doubler which delivers approximately 400 volts. The negative lead is returned to chassis through a low total DC resistance represented by the color purity coil circuits and the field neutralizing circuits. The negative return provides a 2 to 3 volt bias for use in various portions of the receiver.

ALIGNMENT

The following data includes the alignment of the RF, IF, audio IF, chroma amplifier and subcarrier generator circuits. The procedure also includes the adjustment of the matrixing controls, i.e.: R-Y gain, G-Y gain and G-Y ratio.

RF ALIGNMENT

1. The RF tuner may be aligned without removing it from the main chassis. Disconnect the 300-ohm transmission line from the antenna input transformer, T107 and disconnect the B plus to the oscillator.
2. Connect the sweep generator to the RF tuner antenna input transformer using the G-E ST-8A balanced adapter to obtain 300 ohms output, see figure 6. The adapter should be connected to the RF tuner through approximately three feet of 300-ohm transmission line and a resistor pad, as shown in figure 3. When using other test equipment of the unbalanced output type, a pad as shown in figure 8 should be used instead.

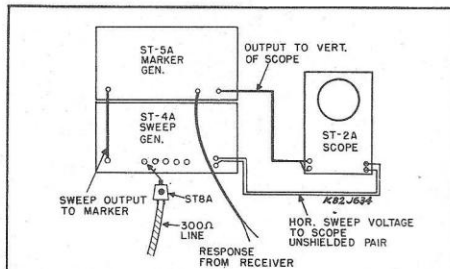

FIG. 6. RF SWEEP EQUIPMENT CONNECTION DIAGRAM

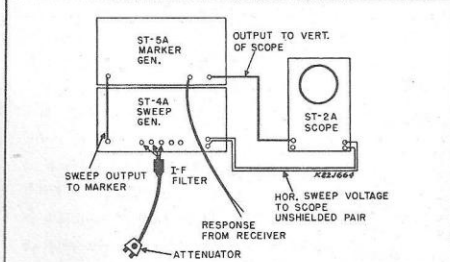

FIG. 7. IF SWEEP EQUIPMENT CONNECTION DIAGRAM

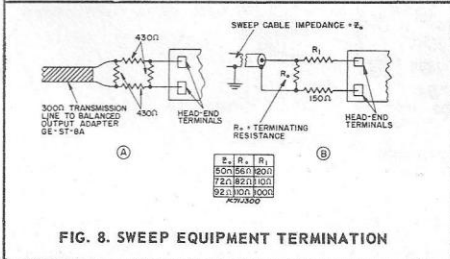

FIG. 8. SWEEP EQUIPMENT TERMINATION

3. Connect a 3-volt battery to the AGC terminal of the RF tuner, with the positive lead of the battery connected to the tuner chassis.

4. Should it become difficult to obtain proper tracking on channels 7-13 with the indicated adjustments, proper tracking may be achieved by adjusting the coil L157. If necessary, L153 and L121 should be knifed to provide correct response on channel 7, after C104, C106 and C108 have been correctly adjusted for channel 12. These coils should be dressed with an insulated tool to prevent a B plus short.

5. It is possible to obtain two different settings of C105, that will give the proper RF bandwidth. The correct setting may be determined by switching from channel 13 to channel 12 and observing the change in bandwidth. The correct setting will result in a slightly greater bandwidth on channel 12.

6. When proper tracking on the low channels cannot be achieved with the provided screw adjustments, the inductance of the coils, L108, L110, L111, L115, L117, L118, L144, L146, and L158 may be varied by inserting a knife blade between the windings. This method of adjustment requires the removal of the tuner shield, a procedure which will detune the circuits. However, in most cases the provided screw-type adjustments will suffice to achieve proper tracking through all channels after the shield has been replaced.

7. The picture and sound carrier marker should not be less than 90% of the peak of the RF response curve. Refer to the "limits" curves shown in the accompanying alignment chart.

8. Seal trimmer screws of C105 and the brass cores in the coils L114, L112, L119, L145, L109, L155, L159, with wax to prevent detuning. Seal the tuning screws in trimmers C104, C106, and C108, with glue. Reconnect the B plus oscillator lead on the RF tuner terminal board and connect the transmission line to RF tuner input transformer.

9. For receiver over-all alignment check, see IF Alignment Chart.

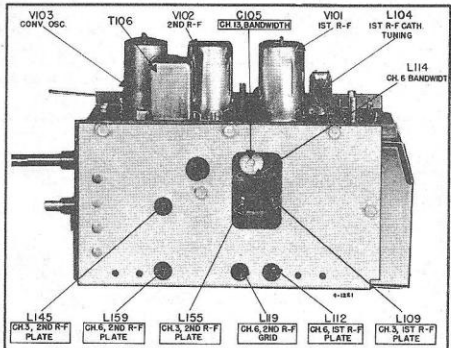

FIG. 9. RF TUNER ADJUSTMENTS, SIDE VIEW

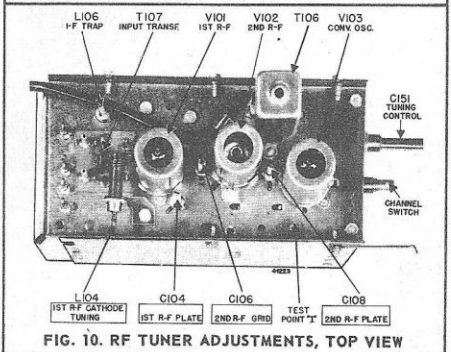

FIG. 10. RF TUNER ADJUSTMENTS, TOP VIEW

15CL100 (COLOR MODEL)

RF ALIGNMENT CHART

OSCILLATOR

- (a) Set generator sweep width to 10-15 mc.
- (b) Signal input point at RF tuner input transformer, T107.
- (c) Observe response curve at test point 1, figure 10, thru 10,000 ohm resistor. Connect test equipment ground lead to RF tuner chassis.
- (d) Adhere to following order when performing a complete alignment.

(e) When following the procedure below, an attempt should be made to obtain the indicated ideal response curves. Minor deviations from the ideal curves may occur, the maximum limits of "tilt" and/or bandwidth being shown in the "Remarks" column.

GENERAL: Two methods of oscillator frequency adjustment are given below. The first method uses a transmitting station for the adjustment while the second method requires a sweep generator to align the oscillator coils.

A. "ON" STATION SIGNAL ALIGNMENT

RF and video IF alignment must be correct before attempting oscillator alignment. A transmitted station signal is needed for each one of the coils being adjusted. Tune in the stations starting with the highest frequency channels and adjust the tuning screws for all available stations so that with the fine tuning control in the full-clockwise position, audio is just visible in the picture. Then, check to see that best picture response on all channels takes place approximately in the center of the oscillator fine tuning range.

B. SWEEP ALIGNMENT

1. RF and video IF must be properly aligned before aligning the oscillator.
2. Connect a 3 volt battery to the AGC terminal of the RF tuner with the positive lead of the battery connected to the tuner chassis.
3. Disconnect the 300 ohm transmission line from the antenna terminals to the RF terminals and connect the sweep generator to the RF tuner terminals as described in note 2 under RF Alignment.

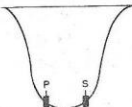
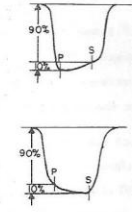
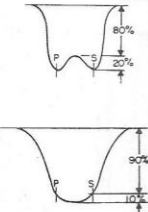
STEP	R'cvr. & Sweep Gen. Channel	Marker Generator Frequency MC	ADJUST	REMARKS AND LIMITS	
1	No. 12	205.25 209.75	C104, C105 and C108 (Fig. 4 & 5) for maximum gain and proper bandwidth of 4.5 mc. to obtain curve "A" below. Limits are shown in last column.	Retune C108 and/or L157 for proper tracking; see Note 4; C105 controls bandwidth, C104, C106 and C108 brings circuits into resonance.	
2	No. 13	211.25 215.75	No adjustments; check tracking; obtain curve "A"; limits shown in last column. See notes 4, 5 and 7.	 "A" Ideal Curve	
3	No. 11	199.25 203.75			 Tilt Limit Curves
4	No. 10	193.25 197.75			
5	No. 9	187.25 191.75			
6	No. 8	181.25 185.75			
7	No. 7	175.25 179.75			
8	No. 6	83.25 87.75			
9	No. 5	77.25 81.75	No adjustments, check tracking;	 Bandwidth Limit Curves	
10	No. 4	67.25 71.75	see curve "B" and Notes 6 & 7.		
11	No. 3	61.25 65.75	L109, L155 and L145 for maximum gain and optimum curve flatness. See curve "B".		
12	No. 2	55.25 59.75	No adjustments, check tracking; See curve "B".		

OSCILLATOR ALIGN

STEP No.	R'cvr. & Marker Position	Marker Generator Frequency	SIGNAL INPUT POINT	OBSERVE RESPONSE CURVE AT
13	No. 13	211.25 MC	Antenna terminals (see Note 3)	Test Point 4 (video detector diode load)
14	No. 12	205.25 MC		
15	No. 11	199.25 MC		
16	No. 10	193.25 MC		
17	No. 9	187.25 MC		
18	No. 8	181.25 MC		
19	No. 7	175.25 MC		
20	No. 6	83.25 MC		
21	No. 5	77.25 MC		
22	No. 4	67.25 MC		
23	No. 3	61.25 MC		
24	No. 2	55.25 MC		

VIDEO IF ALIGNMENT

The following alignment data is divided into two separate procedures. Because of the extremely high adjacent channel trap attenuation, the conventional method of sweep observation of these traps becomes difficult. Hence all traps shall be pretuned by applying an amplitude-modulated signal and adjusted for minimum signal output.

The second portion of this procedure involves the shaping of the RF response curve in the conventional manner by the application of a sweep generator signal. During this procedure, observe the usual precautions regarding warm-up time, equipment cable lead dress and generator output cable termination, see figure 3.

TRAP ALIGNMENT

General: As noted above, an AM signal is required for trap alignment. In many cases, the technician will have a suitable AM signal generator available. It should cover the range of 37 to 48 megacycles at fundamental frequency,

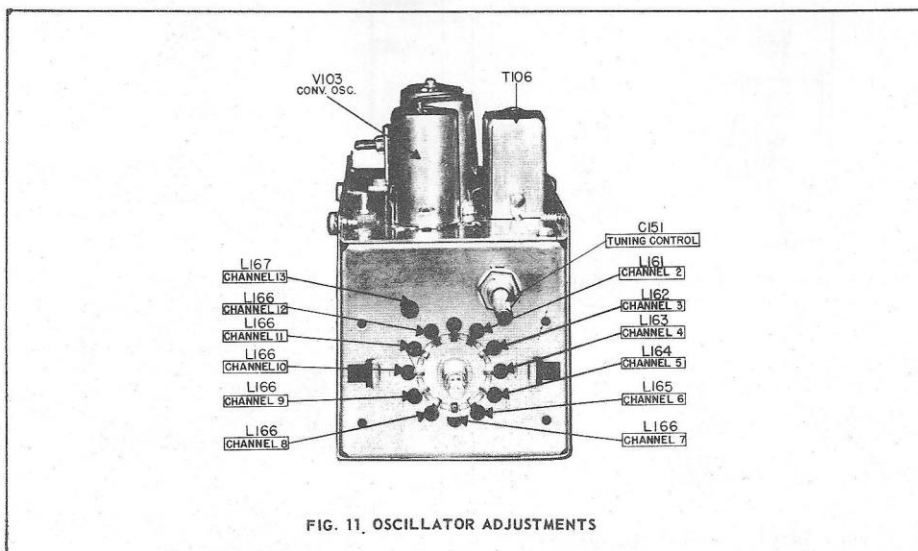

FIG. 11. OSCILLATOR ADJUSTMENTS

ALIGNMENT

4. Set the fine tuning knob 180 degrees (½ turn) from the counter-clockwise limit of its rotation, i.e., rotate the fine tuning knob counter-clockwise to the end of its travel, then turn the fine tuning control knob 180 degrees (½ turn) clockwise. This setting of the fine tuning control should be maintained for all oscillator adjustments.

5. Make the indicated adjustments so that the picture carrier marker for the channel falls at 50% on the high frequency side of the response curve.

ADJUSTMENT CHART

ADJUST	SEE NOTE
67 Channel No. 13 oscillator adjustment.	1, 2, 3, 4, 5
66 Channel No. 12 oscillator adjustment.	
66 Channel No. 11 oscillator adjustment.	
66 Channel No. 10 oscillator adjustment.	
66 Channel No. 9 oscillator adjustment.	
66 Channel No. 8 oscillator adjustment.	
66 Channel No. 7 oscillator adjustment.	
65 Channel No. 6 oscillator adjustment.	
64 Channel No. 5 oscillator adjustment.	
63 Channel No. 4 oscillator adjustment.	
62 Channel No. 3 oscillator adjustment.	
61 Channel No. 2 oscillator adjustment.	

with available internal 400-cycle modulation. When this type of signal is used, the traps should be adjusted for minimum 400-cycle signal as observed on the oscilloscope.

Owners of General Electric sweep alignment equipment may obtain the required amplitude-modulated carrier frequencies by a simple manipulation of the equipment controls as noted below.

Those technicians who do not have either of the above equipment available are advised to omit the trap alignment procedure. With the exception of the video amplifier 4.5 mc trap L161, the traps will not become seriously mis-aligned due to tube changes. The above-mentioned 4.5 mc trap may be sweep aligned, if desired, in which case a 4.5 mc sweep signal should be used in step 3, of trap alignment chart. The trap may then be tuned to minimum response at 4.5 mc which should be crystal marker calibrated.

Obtaining AM Output From G-E Sweep Equipment:

The General Electric ST-4A Sweep Generator will provide 60 cycle square-wave amplitude modulated signal. To obtain this signal proceed as follows:

1. Turn the sweep generator sweep width control fully counter-clockwise. This will provide a steady (zero sweep) carrier.

2. Turn the sweep generator blanking switch "On". This will square-wave modulate the carrier at a 60 cycle rate.

3. The next step is to calibrate the frequency of this AM carrier.

a) Turn the marker generator "On" and set the dial to the desired frequency (4.5 mc, 38.0 mc, 41.25 mc, or 47.25 mc).

b) Slowly tune the sweep generator through the desired frequency. As the desired frequency is approached, a strong beat signal will be observed on the oscilloscope. At exact resonance, a zero beat condition will be noticed on each side of which will appear a beat pattern. Minor sweep generator back and forth frequency drift may be noted. However, this drift is insignificant and may be disregarded.

c) Turn off the marker output.

4. Apply this AM signal according to the instructions in the chart below.

5. The signal observed on the oscilloscope appears as two parallel lines. When the traps are properly tuned the distance between these lines will be at a minimum.

NOTE: It may be necessary to use full output of the sweep generator and near maximum oscilloscope gain to observe proper trap tuning.

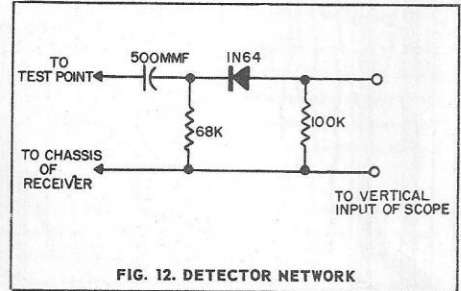

FIG. 12. DETECTOR NETWORK

STEP	AM-GENERATOR INPUT POINT	AM-GENERATOR FREQUENCY	ADJUST	REMARKS
1	Connect AM signal generator to TEST POINT 1 through .001 mf capacitor.	41.25 MC	L152 For minimum output	Connect oscilloscope to Test Point 5 for Step 1 and 2.
		47.25 MC	L153	
		41.25 MC	L158	
2		39.75 MC	L151 For maximum output	38.0 mc trap over-shoot actually sets sound shelf.
3	Connect AM signal generator to TEST POINT 5.	4.5 MC	L161 For minimum output	Connect detector network, Fig. 7. Between oscilloscope input and receiver Test Point 20. Remove V107. Set Contrast control at maximum.
4		3.58 MC	L201 For minimum output	

TRAP ALIGNMENT CHART

IF SYSTEM SWEEP ALIGNMENT

GENERAL: After the traps have been set at their proper frequencies the IF curve may be shaped.

NOTES:

1. Turn Picture Contrast control to minimum.
2. Connect oscilloscope to Test Point 4 through 20,000 ohms resistor. (It is necessary to shift oscilloscope from TP 4 to TP 5 to observe both sets of IF curves.)
3. Apply a negative 4½ volt battery bias voltage to Test Point 4 throughout IF alignment.
4. Calibrated scope for 2" deflection with ¾ volt signal.
5. Note that the following procedure uses 45.0 mc as the 10% reference point. Maintain the sweep generator output so that the baseline-to-45.0 mc marker amplitude equals 2 inches. Align as indicated in the alignment chart.

ALIGNMENT NOTES:

1. Remove the horizontal output tubes V131 and V132 from their sockets being careful that the plate connectors do not short to the chassis.
2. Remove the sync amplifier and noise canceller tube V113 from its socket.

3. Turn volume control and brightness control to minimum. Turn Contrast control to maximum.

4. Set channel selector to channel 11 position with Fine Tuning at the maximum clockwise position.

5. Connect oscilloscope in series with 20,000 ohm ½ watt carbon resistor to indicated Test Points. (20,000 ohm resistor is used throughout IF alignment.)

6. Allow receiver and test equipment to warm up at least 20 minutes. (Refer to Tube and Trimmer location drawing for adjustment locations.)

AUDIO IF ALIGNMENT

NOTES:

1. Tune in a television signal. This will provide a 4.5 mc signal source for audio alignment. Keep the Volume control turned down unless the speaker is connected.

2. Figure 13 shows a simple resistor network needed for the alignment of T402 secondary. These two 100K resistors should be chosen as accurately as possible, for equal resistance. Be sure to remove these resistors after completing the alignment. Align as shown in chart.

IF ALIGNMENT CHART				
Step	CONNECT SWEEP GENERATOR	ADJUST or PEAK	DESIRED RESPONSE	REMARKS
1	Into Test Point 3 and chassis through .001 mf capacitor. Center sweep frequency approx. 44.0 mc. Sweep width approx. 10 mc.	L159 for maximum at 43.1 mc. L155 for maximum at 45.6 mc.		Observe response at Test Point 4. Make indicated adjustments to obtain maximum gain consistent with proper curve. Corners of curve peak must show slight rounding.
2				Check with scope on Test Point 5 for indicated response. It may be necessary to alternate scope observation between Test Points 4 and 5 to achieve proper response curves.
3	Into Test Point 1 & chassis through .001 mf capacitor. Center sweep frequency approx. 44.0 mc. Sweep width approx. 10 mc.	T153 for max at 42.2 mc T152 for max at 41.6 mc T151 for maximum at 45.15 mc T106 for maximum at 45.75 mc L154 for maximum at 43.8 mc		Check with scope on TEST POINT 5 for indicated curve. Adjust T151 to set 45.75 mc at 45%. Adjust L159 to set 42.5 mc at 55%. Adjust L154 for good symmetry (No Tilt) at peak region of curve.
4	Sweep width approx. 10 mc.	See remarks columns.		Check with scope on Test Point 4 for indicated curve. If necessary. Adjust L151 to set 39.75 mc as shown. Adjust T153 to set flat "shelf" about 42.2 mc. Alternate scope between Test Points 4 & 5 while making minor adjustments to obtain both proper curves of steps 3 & 4.
5	Into RF tuner input through balanced adapter & 300-ohm pad & line. Sweep channels 10 & 5. Sweep width approx. 10 mc.	C108 (RF tuner)		Align for zero "tilt" on ch. 10. Check chs. 7-13 and make further compromise adjustment so that each channel will have no more than 10% "tilt" with the Fine Tuning adjusted to provide the proper sound and picture IF markers.
6		L145-L159 (R-F Tuner)		Align for zero "tilt" on channel 5. Check channels 2-6 and make further compromise adjustment, so that each channel will have no more than 10% "tilt" with the Fine Tuning adjusted to provide the proper sound and picture IF markers.

INTRODUCTION: The purpose of the Chroma Channel is to amplify the relatively low-detail color subcarrier information to the synchronous detectors and the subcarrier generating systems. The bandwidth of the Chroma Channel is quite narrow, being approximately 1.2 mc wide, measured at the maximum corner points of its amplitude response. It is most important that the 3.0 mc and 4.2 mc "corners" be accurately set since the .8 usec. delay incorporated in the "Y" channel is predicated upon the 1.2 mc passband of the chroma channel. Also, the 4.5 mc response must be at an

CHROMA CHANNEL ALIGNMENT		
Step	CONNECT SIGNAL	ADJUST
1		L302 for maximum at 3.58 mc.
2	Apply AM signal through .001 mf capacitor to Test Point 4.	L301 for minimum at 4.5 mc.
3		T301 secondary (bottom core) for maximum at 4.2 mc.
4	To Test Point 4 connect sweep generator through a .001 mf capacitor.	T302 secondary (bottom core) to position 4.2 mc on corner as shown. T302 primary (top core) to flatten curve.
5	Center sweep approx. 3.5 mc. Sweep width 5 mc.	T301 primary (top core) to "fill in" curve as shown. Adjust secondary (bottom core) to position 4.2 mc.

SUBCARRIER GENERATOR ALIGNMENT

The alignment of this section of the receiver essentially consists of peaking the various tuned circuits to 3.58 mc as indicated by means of VTVM DC voltage readings. This procedure requires the use of a stable 3.58 mc crystal controlled signal from a suitable generator, or else it may be performed while the receiver is tuned to a station which is broadcasting a color program.

GENERAL: Before tuning the various circuits in the subcarrier generating system, a check should be made to assure that the gating pulse of the burst gate is properly phased. This can only be done while tuned to a color program or to a signal from a suitable color bar generator.

- 1) Tune receiver to color signal for normal picture.
- 2) Connect wide-band oscilloscope to Test Point 6. If wide band oscilloscope is not available connect network shown in figure 14 to input cable of General Electric ST-2A oscilloscope. This network increases the relative scope gain at 3.58 mc to allow easier observation of the burst signal. Tune the network coil to provide maximum 3.58 mc amplitude.

- 3) Adjust horizontal oscillator coil core (L501) so that picture locks in horizontally on weak signal as channel selector is switch on and off channel.
- 4) Adjust C515 (horiz. detector phasing) so that gate pulse is centered beneath burst signal as observed on oscilloscope. Composite signal should appear as shown in figure 10.

NOTE: Some early production receivers do not incorporate C515. In such receivers, the horizontal oscillator coil should first be adjusted to provide proper horizontal picture sync lock-in, and then be further adjusted to provide gate pulse and burst coincidence as shown in figure 15.

AUDIO IF ALIGNMENT CHART				
Step	CONNECT VTVM or 20,000 ohms/volts METER	ADJUST	METER INDICATION	REMARKS
1	To test point 7 and chassis	L401 and T401 (top and bottom cores)	Adjust for maximum deflection.	Voltage to be read is negative with respect to chassis.
2	V124A, pin 2 and chassis	T402 primary (bottom core)		
3	Test Point 8 & center of two 100,000 ohm resistors. See Fig. 8.	T402 secondary (top core)	Adjust for zero volts DC output.	Repeat Steps 1, 2 & 3 to assure proper final adjustment.

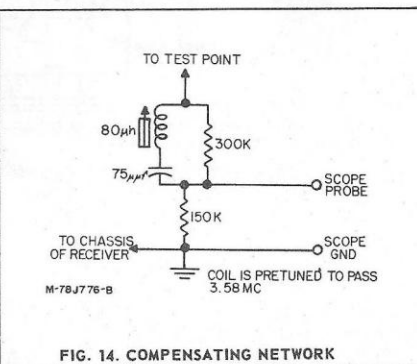
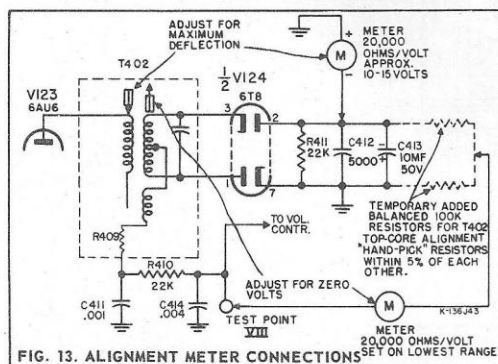

15CL100 (COLOR MODEL)

ALIGNMENT

absolute minimum to prevent "900 KC" beat interference in the chroma channel. Be sure that the 4.5 mc marker lies on the response baseline as shown in the accompanying alignment chart.

NOTES:

1. Connect -15 volt bias supply between Test Points 4 and 23 and ground.
2. Connect scope with detector network, (Fig. 7) to Test Point X.

ALIGNMENT CHART

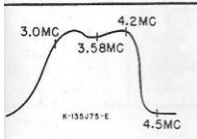
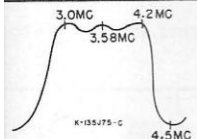
DESIRED RESPONSE	REMARKS
	Repeat steps 1, 2 and 3.
	Check 3.0 mc point and adjust T302 secondary (bottom core) for desired curve.
	Minor saddles may occur on response peak. Duplicate curve as closely as possible.

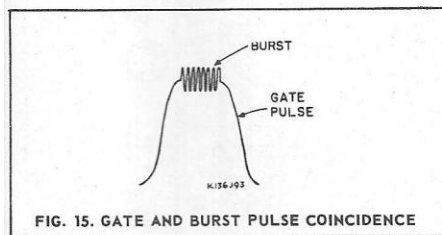

For those interested, a simple oscillator may be constructed according to the schematic diagram of Fig. 16. In this circuit a crystal of the type incorporated in the color receiver may be used. When using a signal of this type to align the sub-carrier channel, insert the signal into test point 4 (chroma detector circuit).

PROCEDURE:

1. Tune receiver to transmitted color program or insert 3.58 mc signal as noted above.
2. Set chroma gain and contrast control fully counter-clockwise.
3. Set Hue control capacitor (C336) to the middle of its range. Maintain this adjustment throughout remainder of procedure. This may require loosening of the Hue control shield. Move shield back just far enough to observe capacitor plates.
4. Adjust bottom core screw of T304 for exactly one inch exposure, measured from the core retaining clip to the slotted end of the core screw.
5. Place VTVM on Test Point 7 through 2.2 megohm resistor. Set T304 top core screw 1/2" out measured between the top core screw clip and the slotted end of core screw.
6. Tune L303 for maximum VTVM reading.

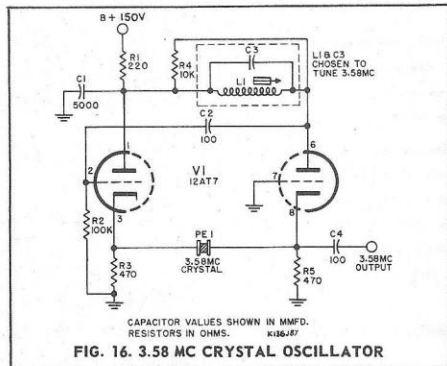

7. Adjust T304 top core for maximum VTVM reading.
8. Repeat steps 6 and 7 twice.
9. Peak L304 for maximum VTVM reading.
10. Connect VTVM through 2.2 megohm resistor to Test Point 24. Peak L305 for maximum VTVM reading.
11. Disconnect 3.58 mc signal source (generator or color program). Tune receiver for normal picture on monochrome signal. Turn contrast and chroma controls fully counter-clockwise and increase brightness control so that blank raster is visible.

Disable color killer circuits by by-passing plate of V120B (Pin 1) to chassis through .1 mf capacitor. Reduce picture width to minimum and adjust horizontal centering control so left edge of raster is visible.

Adjust the neutralizing capacitor C318 (below chassis) to remove tunable noise effects or striations at the left edge of the raster. The tuning effects of C318 are most pronounced and are therefore easily seen.

PHASING OF SYNCHRONOUS DETECTORS

If a color bar generator is not available for this procedure, turn the receiver station selector to a channel which is transmitting a color program or the standard color bar test signal. Make sure the "Hue" control is set in the middle of its range.

1. Couple a 45.75 mc signal to the input of the 1st IF amplifier tube V104. Adjust the fine tuning control for zero beat between the two 45.75 mc carriers. Leave tuning control set, as is, and disconnect 45.75 mc generator lead.
- NOTE:** The following procedure requires use of VTVM, on receivers incorporating common detector cathode connection as shown on schematic inset, connect VTVM ground lead to junction of R266 and R631 instead of to chassis. Other lead of VTVM should be connected as indicated below.

- a) Adjust the top slug of T303 all the way out.
- b) Connect a VTVM through a 2.2 meg resistor to test point 10. (Pin 1 of V121).
- c) Tune the bottom slug of T303 for maximum DC voltage reading on the VTVM.
- d) Connect VTVM through a 2.2 meg resistor to test point 14. (pin 1 of V116).
- e) Tune the top slug of T303 for a maximum DC voltage reading on VTVM.
- f) Repeat steps b, c, d, and e.

Steps "a" through "f" above, will bring the detectors very closely into phase and in many cases will suffice to provide good color accuracy. Should viewed programs or color bars appear slightly in error with respect to color accuracy (after matrixing procedure, below, has been accomplished),

adjust "Hue" control for color correction. Should the need for more accurate color phasing be indicated, follow the procedure listed below for accurate detector phasing.

2. Tune receiver to color bar pattern. Set "Hue" control to middle of its range.
3. Adjust fine tuning control according to item 1, above.

NOTE: The following adjustments require that the technician be familiar with the sequence of colors and other information contained in the color bar pattern used. In the following procedure, the adjustments are made to "zero-set" the amplitude of the R-Y and B-Y bars. Proper phasing of the 90 degree displaced gating subcarrier voltages will produce zero B-Y output signal in the R-Y channel and zero R-Y output signal in the B-Y channel.

In the event that R-Y and B-Y bars are not included in the available color bar pattern, only the preceding "DC" alignment should be used and the following steps 4, 5 and 6 may be disregarded.

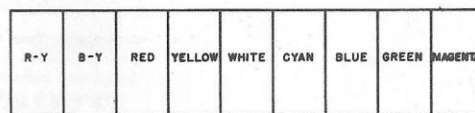

4. Connect scope synced at the horizontal sweep line rate to Test Point 15 (B-Y Amp.). Figure 17 indicates the possible sequence of information contained in a color bar test pattern. Tune the primary (bottom core) of T303 until zero amplitude of the R-Y bar is obtained as shown in Figure 18.

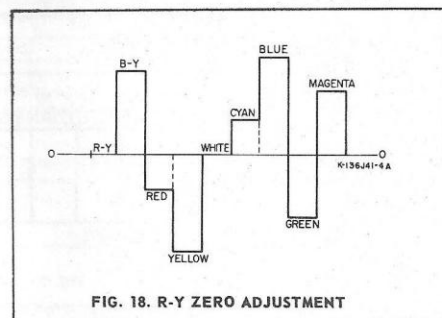

5. Connect scope synced as above, to Test Point 16 (R-Y Amp.). Tune secondary (top core) of T303 until zero amplitude of the B-Y bar is obtained as shown in Figure 19.
6. Repeat steps 4 and 5 above, to assure accurate quadrature voltage phase angle setting.
7. Note: On receivers equipped with hum canceller control, R631, remove all signal input to receiver. Connect scope to test point 19 and adjust R631 for minimum 60 cycle hum output.

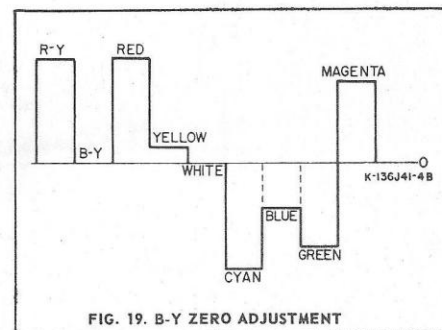

15CL100 (COLOR MODEL)

RECEIVER MATRIXING PROCEDURE

The term "matrixing" applies to those circuits which perform the function of combining the various color difference signals, in proper proportions, to eventually form the red, green and blue picture tube driving voltages.

Specifically, the R-Y and B-Y voltages are first adjusted in amplitude and then, from these proportioned voltages, the G-Y voltage is formed and adjusted in amplitude. It should be noted that misadjustment of the matrixing controls will cause erroneous picture color information just as readily as if the individual detector gate phases were improperly adjusted.

The following procedure should be followed in the sequence indicated.

1. Set channel selector to a standard color bar test signal. Couple a 45.75 mc signal to the input of the first IF amplifier V104. Adjust the fine tuning control for zero beat between the two 45.75 mc carriers. Leave fine tuning control set, as is and remove 45.75 mc signal lead.

- (a) Turn chroma gain control, R603, fully counter-clockwise.
- (b) Place scope probe at Test Point 18. (pin 18 of V140).

2. Y, B-Y MATRIXING

(a) Adjust the contrast control to center position. Do not move this control again throughout the remainder of the matrixing procedure.

(b) Adjust the Chroma control until the response is like figure 20. Red and yellow should pass through zero at the same time Cyan and blue reach a maximum equal to the amplitude of the white bar. The Chroma control must remain fixed at this setting throughout the remainder of the matrixing procedure.

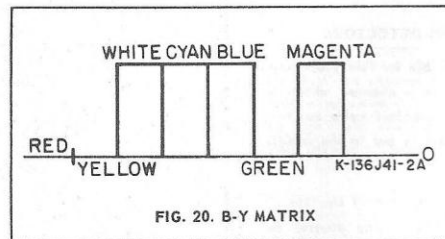

FIG. 20. B-Y MATRIX

3. Y, R-Y MATRIXING

(a) Place scope probe at test point 17, (pin 3 of V140).

(b) Adjust R-Y gain control (R605) until the response resembles figure 21. Red and yellow should reach a maximum equal to white, at the same time Cyan and blue reach zero amplitude.

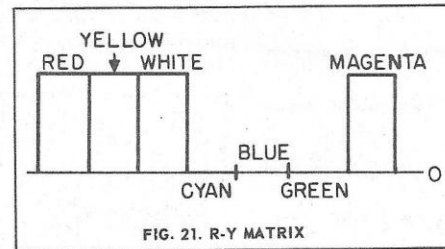

FIG. 21. R-Y MATRIX

4. Y, G-Y RATIO & MATRIXING

(a) Place scope probe on test point 19, (pin 8 of V140).

(b) Short test point 20 to ground. (Grid of V110A).

(c) Adjust the G-Y Ratio control, R606, for the response shown in figure 22. Note that the green and magenta bars

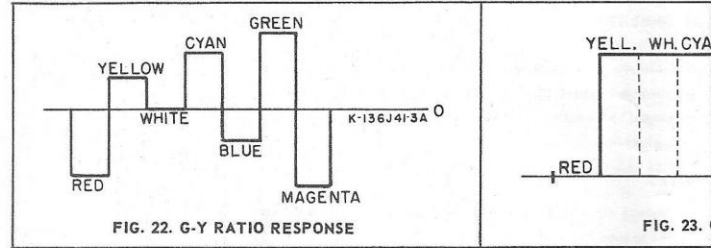

FIG. 22. G-Y RATIO RESPONSE

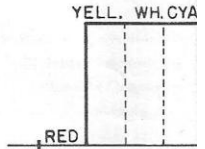

FIG. 23.

are of equal amplitude but opposite polarity, as are the blue and yellow bars.

ADJUSTMENT OF T502 CONVERGENCE

(d) Remove short from test point 20, (pin 9 of V110).

(e) Adjust the G-Y Gain control R607 for the response shown in figure 23. Yellow, green and Cyan should reach maximum equal to white, while red and blue reach zero.

Bring scope probe near lead (probe may be clipped on lead horizontal rate. Peak T502

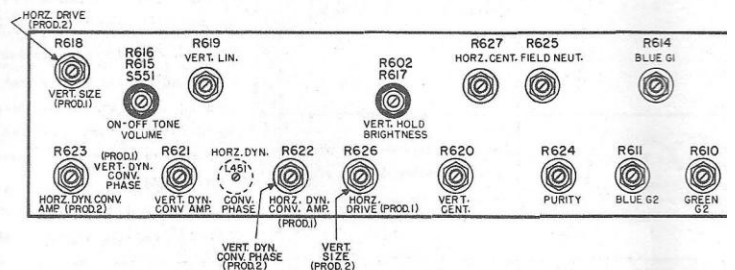
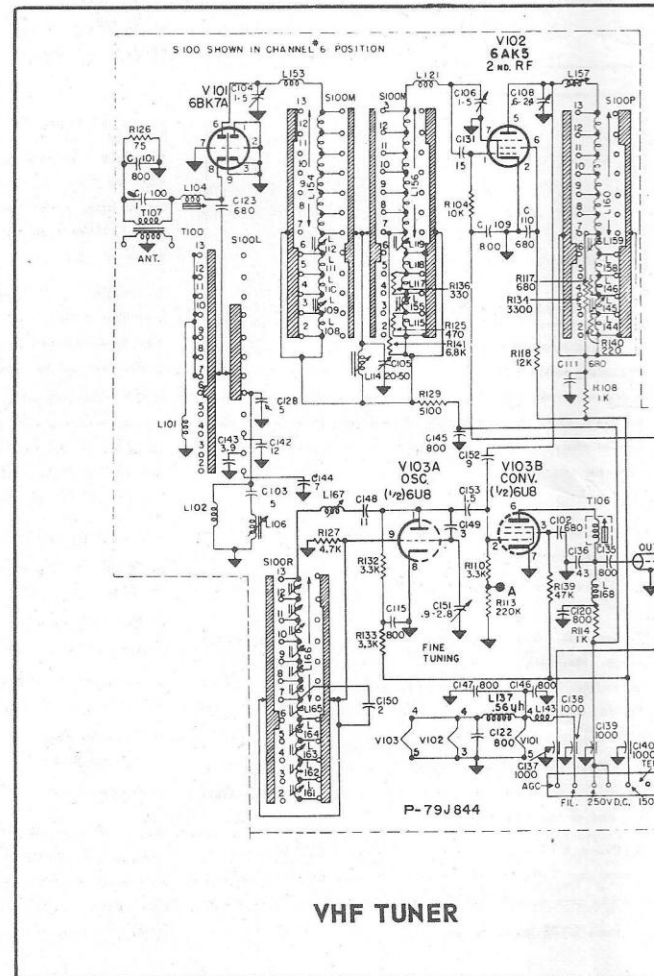
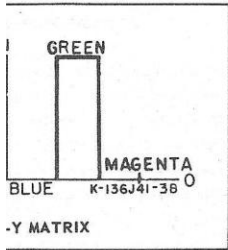

FIG. 24. FRONT PANEL ADJUSTMENTS, (1ST & 2ND PROD.)



VHF TUNER



HORIZONTAL DYNAMIC TRANSFORMER

from T502 to C461 and C465, insulation). Sync scope at 1/2 or maximum output.

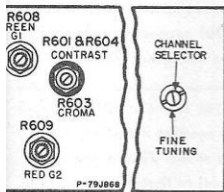

ELECTROLYTIC CONDENSERS		
REF. NO.	DESCRIPTION	PART NO.
C203	5 mfd., 250V	RCE-178
C205	2 mfd., 250V	RCE-179
C206	25-25-25 mfd., 25V, 20 mfd., 150V	RCE-190
C351	1 mfd., 25V	RCE-189
C473	100 mfd., 50V	RCE-183
C526	25-25-25 mfd., 25V,	RCE-184
C551	150 mfd., 250V	RCE-180
C552	300 mfd., 250V	RCE-181
C553	80-30-30 mfd., 450V	RCE-185
C554	50 mfd., 25V	RCE-182
C554	150 mfd., 250V, 40 mfd., 450V, 5 mfd., 250V	RCE-186
C555	100 mfd., 250V, 2 mfd., 75V, 10-10 mfd., 25V	RCE-187
C559	160 mfd., 350V	RCE-191

CONTROLS		
DESCRIPTION	REF. NO.	PART NO.
Master Brightness, 50K ohm	R602	RRC-258
Hor. Drive, 50K ohm	R626	RRC-265
Hor. Cent., 80 ohm C. T., w. w.	R627	RRC-273
Vert. Hold 175K ohm	R617	RRC-258
Vert. Cent., 20 ohm C. T., w. w.	R620	RRC-272
Vert. Lin., 5K ohms, w. w.	R619	RRC-271
Vert. Dynamic Convergence amplitude, 25K ohms	R621	RRC-264
Vert. Dynamic Convergence phase, 5 meg.	R623	RRC-267
Height, 4 meg.	R618	RRC-260
Focus, 5 meg. H. V. insulated	R628	RRC-261
Triple section, dual shaft	R601, 3	RRC-257
1K ohm - 500 ohm & 4	611	RRC-259
Tone, Vol. 500K, 500K carbon dual shaft /AC switch S551	R616, 15	RRC-259
G-Y Ratio -10K ohm carbon	R606	RRC-262
Convergence -15 meg, 1W	R629	RRC-263
H. V. Reg. Adj., 2 meg.	R630	RRC-266
Red, Green, Blue G2 100K ohm	R609 to 611	RRC-268
Green & Blue Gain, 5K ohm	R612, 13	RRC-269
G-Y, R-Y Gain, 200 ohm, w. w.	R605, 7	RRC-270
Color purity, 10 ohm, 4W w. w.	R624	RRC-274
Field Neutralizing, 15 ohm, C. T. w. w.	R625	RRC-275
2K ohm, 5W	R417	RRW-116
1K ohm, 5W	R520	RRW-112
150 ohm, 10W	R523	RRW-111
3 ohm	R526	RRW-117

CONTROLS		
DESCRIPTION	REF. NO.	PART NO.
5.6 ohm	R531	RRW-118
50 meg. H. V. type	R534	RRW-113
55 meg. H. V. type	R535	RRW-114
WIREWOUND		
5K ohm, 5W	R171	RRW-110
2K ohm, 10W	R244	RRW-115

COILS		
REF. NO.	DESCRIPTION	PART NO.
L154	1st Video IF Grid	RLI-256
L155, 6, 8 & 163	Chroma det. ass'y (incl. C168, 9; R166; Y151)	RLX-045
L159, 60	"Y" det. ass'y (incl. R167; C171, 2; Y162)	RLX-046
L164	Comp. choke, 1000 mic.	RLI-261
L202, 4, 6	Choke, 240 mic.	RLI-262
L203, 5, 7	Comp. choke, 150 mic.	RLI-263
L251, 2	Comp. choke, 1,800 mic.	RLI-265
L302	3.58 MC tank circuit	RLI-268
L308	Choke, 68 uh	RLI-260
L401	Sound takeoff, 4.5 MC	RLI-266
L451	Hor. Convergence phas'g	RLI-264
L501	Hor. Oscillator	RLC-130
L502	Width	RLD-062
L503	Hor. Linearity	RLD-063
L553	Color Purity	RLP-023
L555	Field Neutralizing	RLN-003

TRANSFORMERS		
DESCRIPTION	REF. NO.	PART NO.
Vertical Convergence	T503	RLC-131
Hor. Convergence	T503	RTC-001
Hor. Output	T501	RTO-158
Power	T551	RTP-320
Audio IF, 4.5 MC	T401	RTL-160
1st Chroma, 3.58 MC bandpass	T801	RTB-002
2nd Chroma bandpass	T302, 4	RTB-003
3.58 MC	T402	RTD-016
Ratio Detector 4.5MC	T151, 2	RTL-159
1st, 2d, 3d Video IF & 3	T303	RTP-319
3.58 MC Quadrature	DL201	RWD-004
Delay Line -.8 usec		

MISCELLANEOUS		
REF. NO.	DESCRIPTION	PART NO.
LSP401	Yoke	RLD-064
PE301	Speaker 6 1/2" (table mod.)	S-650D
X552	Crystal -3.579545 MC + 100 cycles, quartz	REE-001
X551	Rectifier, selenium 350ma	RER-017
	Rectifier, selenium 600ma	RER-018

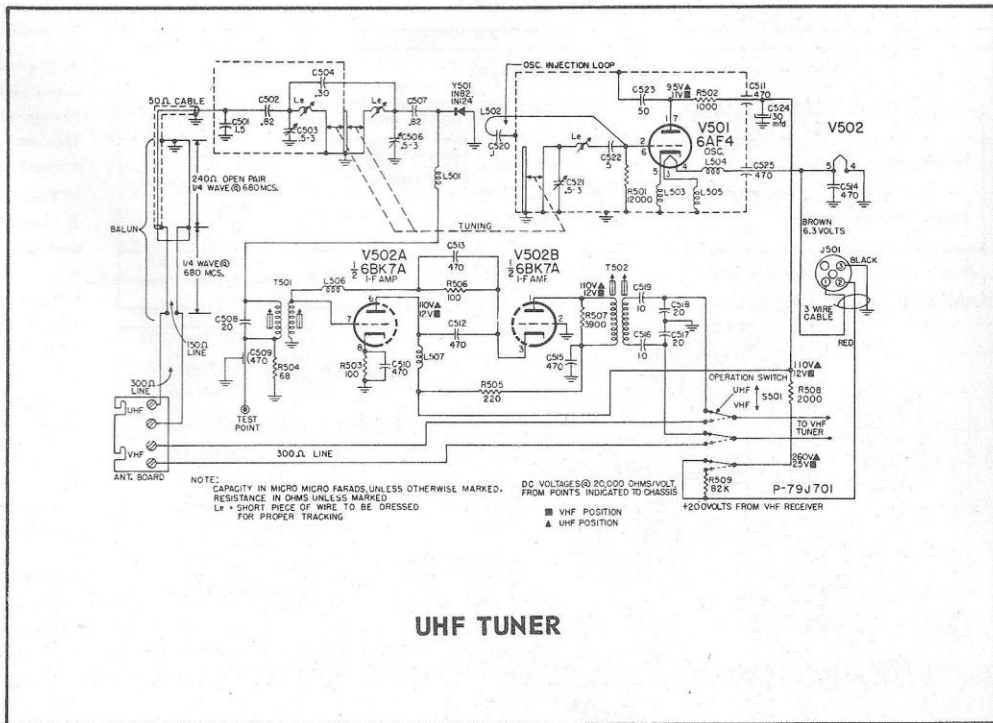
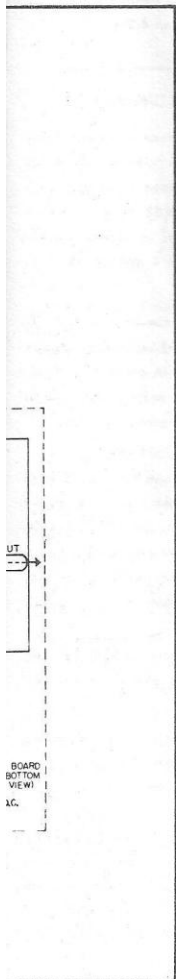

UHF TUNER

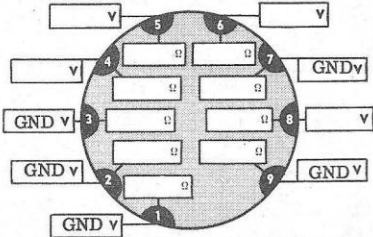

V101 6BK7A RF Amplifier

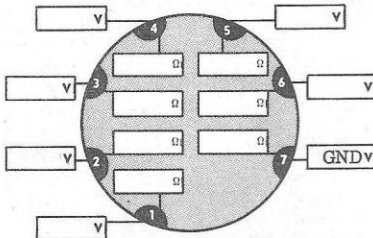

V102 6AK5 2nd RF Amplifier

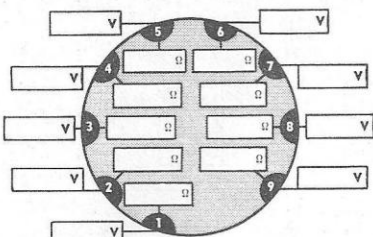

V103 6U8 Converter - Oscillator

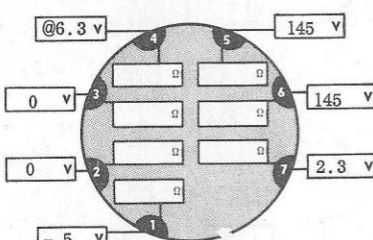

V104 6BA6 1st IF Amplifier

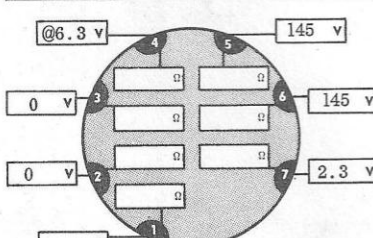

V105 6BA6 2nd IF Amplifier

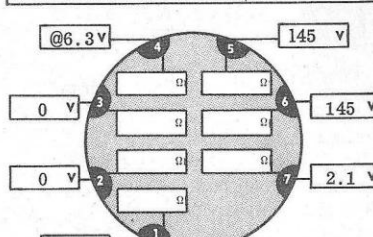

V106 6BA6 3rd IF Amplifier

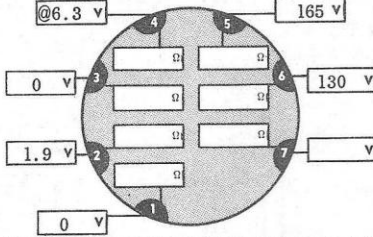

V107 6CB6 4th IF Amplifier

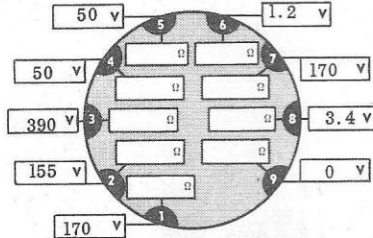

V108 6U8 Y Cath. Follower & Keyer

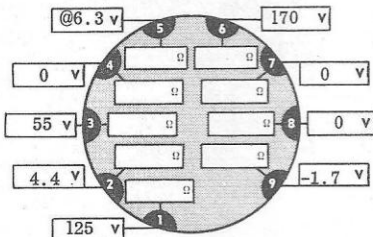

V109 6U8 'Y' Amp., Sync. Clipper

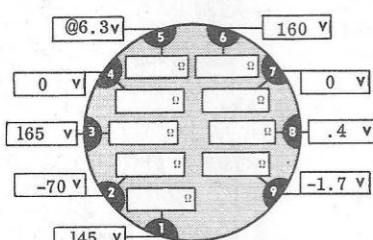

V110 6U8 'Y' Amp. & G-Y Amp.

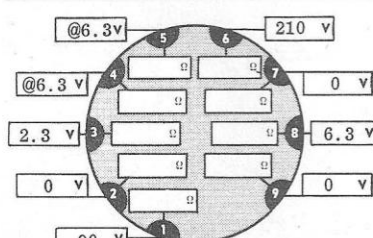

V111 12BH7 Red Output Amplifier

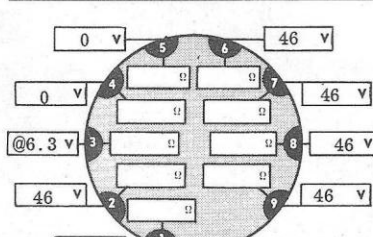

V112 6BJ7 DC Restorer

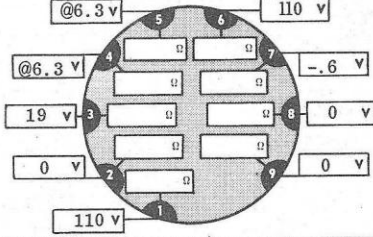

V113 12AT7 Noise Canc. & Sync. Amp.

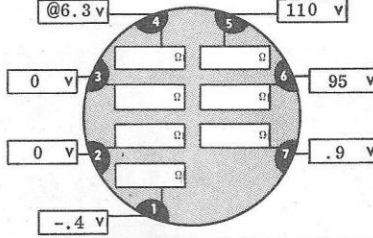

V114 6BA6 Chroma Amplifier

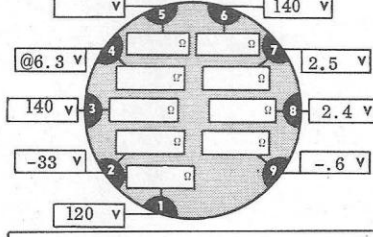

V115 6U8 Chroma Cath. Follower & Burst Gate

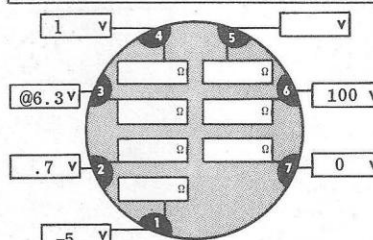

V116 6BE6 R-Y Detector

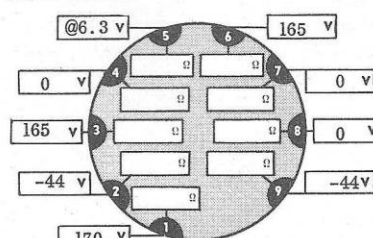

V117 6U8 R-Y, B-Y Amplifier

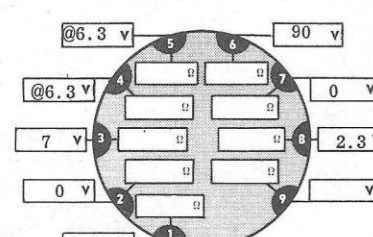

V118 12BH7 Green Output Amplifier

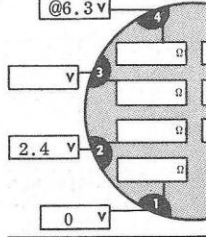

V119 6CB6 Audio

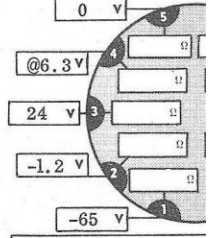

V120 6U8 Subcarrier Color Kill

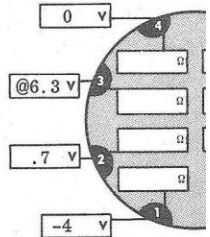

V121 6BE6 B-Y

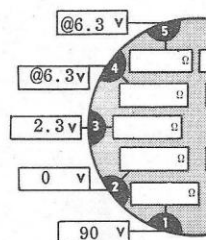

V122 12BH7 Blue

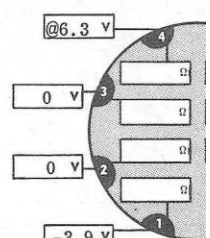

V123 6AU6 Audio

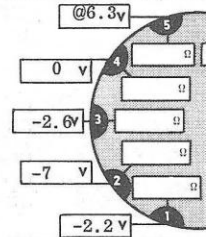

V124 6T8 Ratio Det. Burst Gat.

15CL100 (COLOR MODEL)

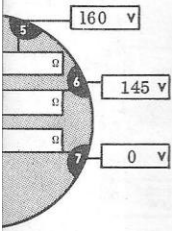

IF Amplifier

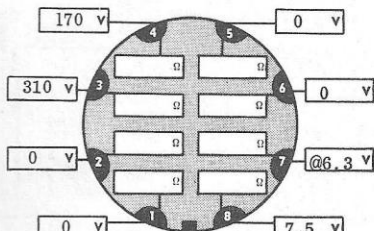

V125 6V6 Audio Output

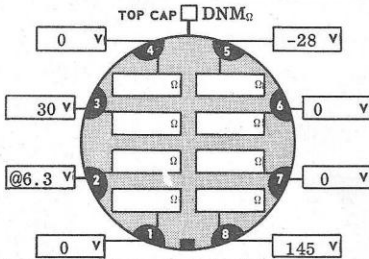

V131 6CD6 Horizontal Output

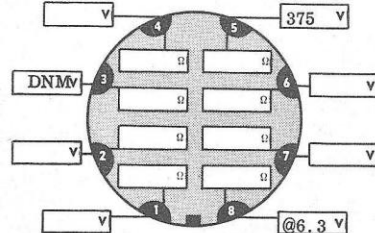

V137 6AU4 Damper

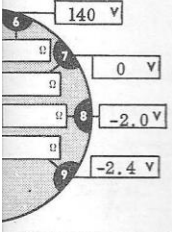

Limiter & ...

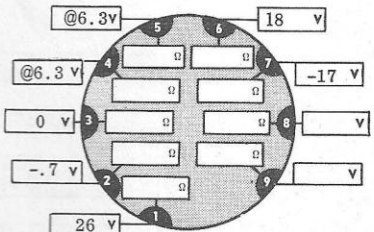

V126 12BH7 Vertical Oscillator

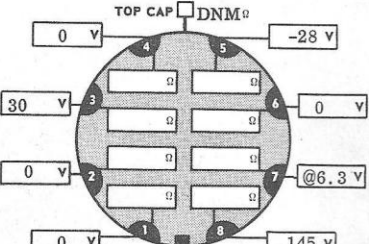

V132 6CD6 Horizontal Output

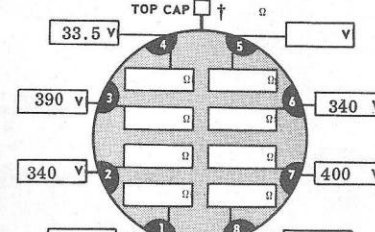

V138 Z2188 High Voltage Rectifier

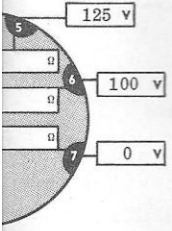

Detector

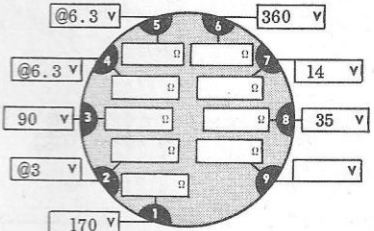

V127 12BH Vert. Output & Blanking

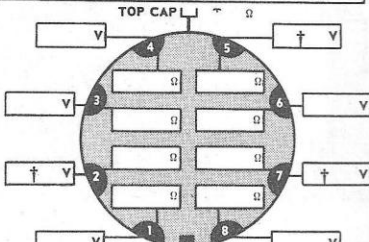

V133 Z2176 H. V. Rectifier

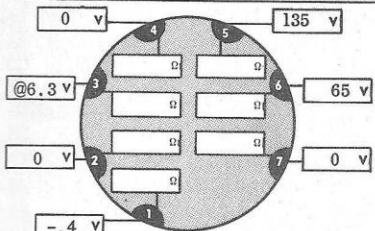

V139 6AU6 Subcarrier Amplifier

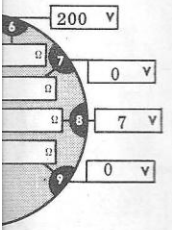

Output Amplifier

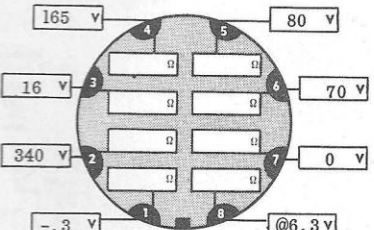

V128 6BL7 Composite Conv., H. Blank

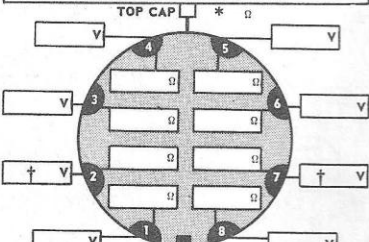

V134 1B3 H. V. Rectifier

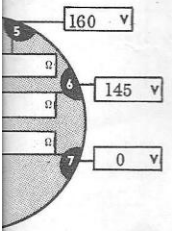

Limiter

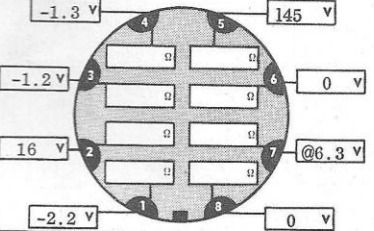

V129 6AQ7 Hor. Phase Detector & Reactance Control

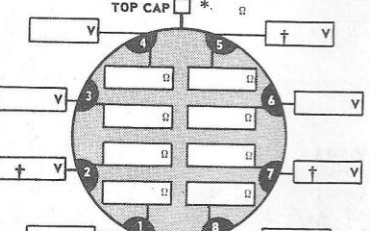

V135 Z2176 H. V. Rectifier

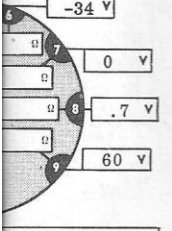

Audio Amp Clamp

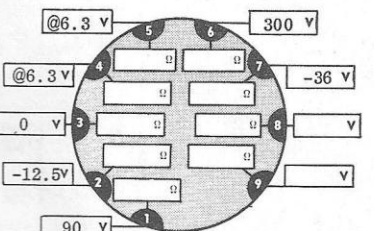

V130 12AU7 Hor. Osc. & Discharge

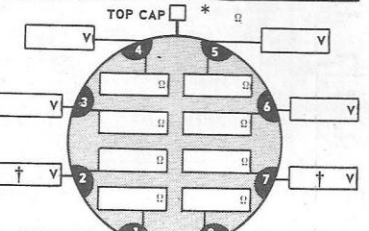

V136 1B3GT Focus Rectifier

TEST CONDITIONS

- @ AC voltage reading.
 - * Plate caps on these tubes are connected to extremely high DC voltages, DO NOT MEASURE.
 - ** These tubes have their filaments tied to some DC potential.
 - † These pins are connected to extremely high DC voltages and should not be measured without special probes capable of measuring at least 30,000 V.
- AC line voltage adjusted for 117 V.
 All readings DC unless otherwise noted.
 All readings with VTVM unless otherwise noted.
 DNM - Do not measure.

COLOR MODEL 15CL100 (First Production)

FOR TUNERS USED ON THIS CHASSIS, SEE PAGE 94.

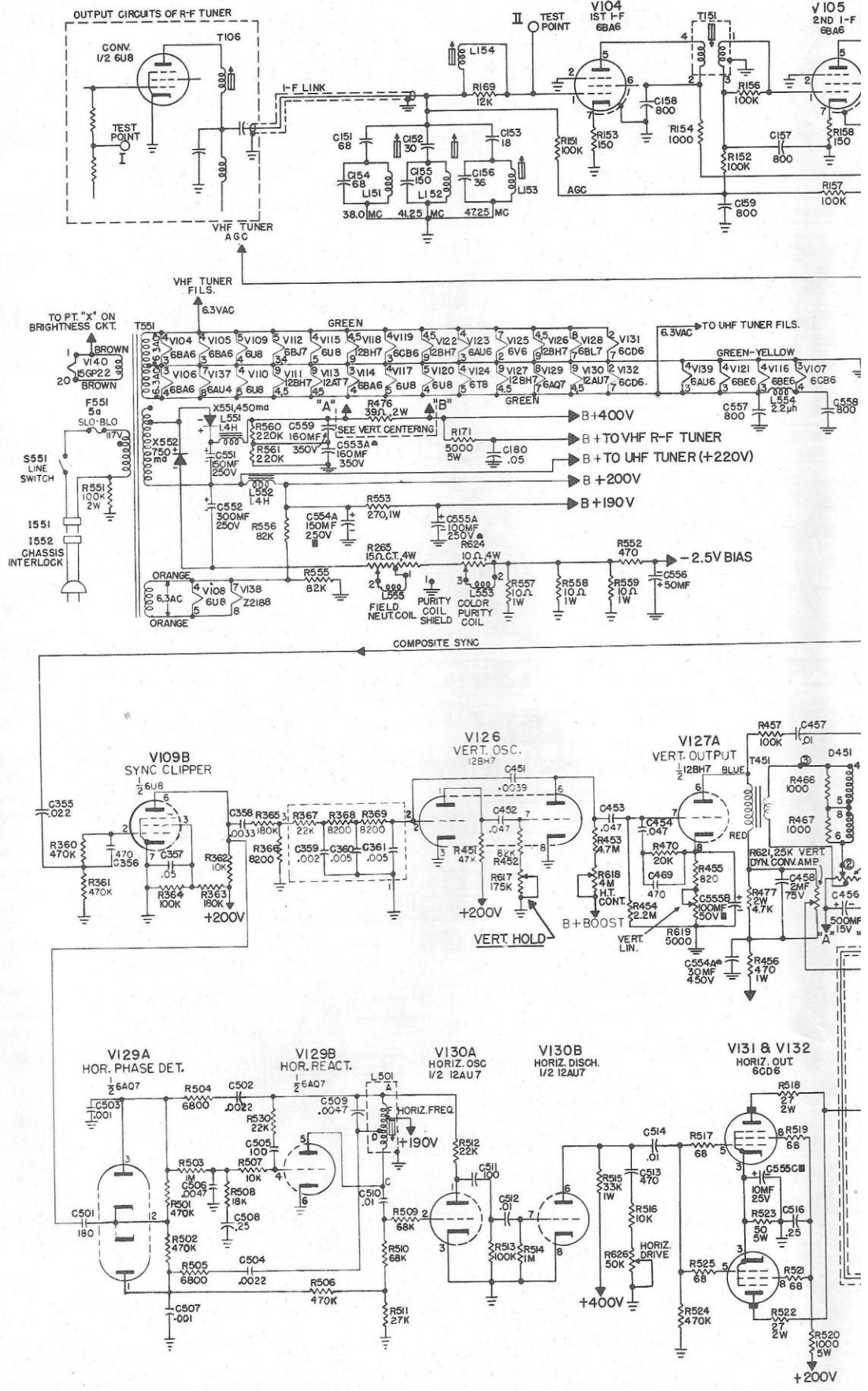

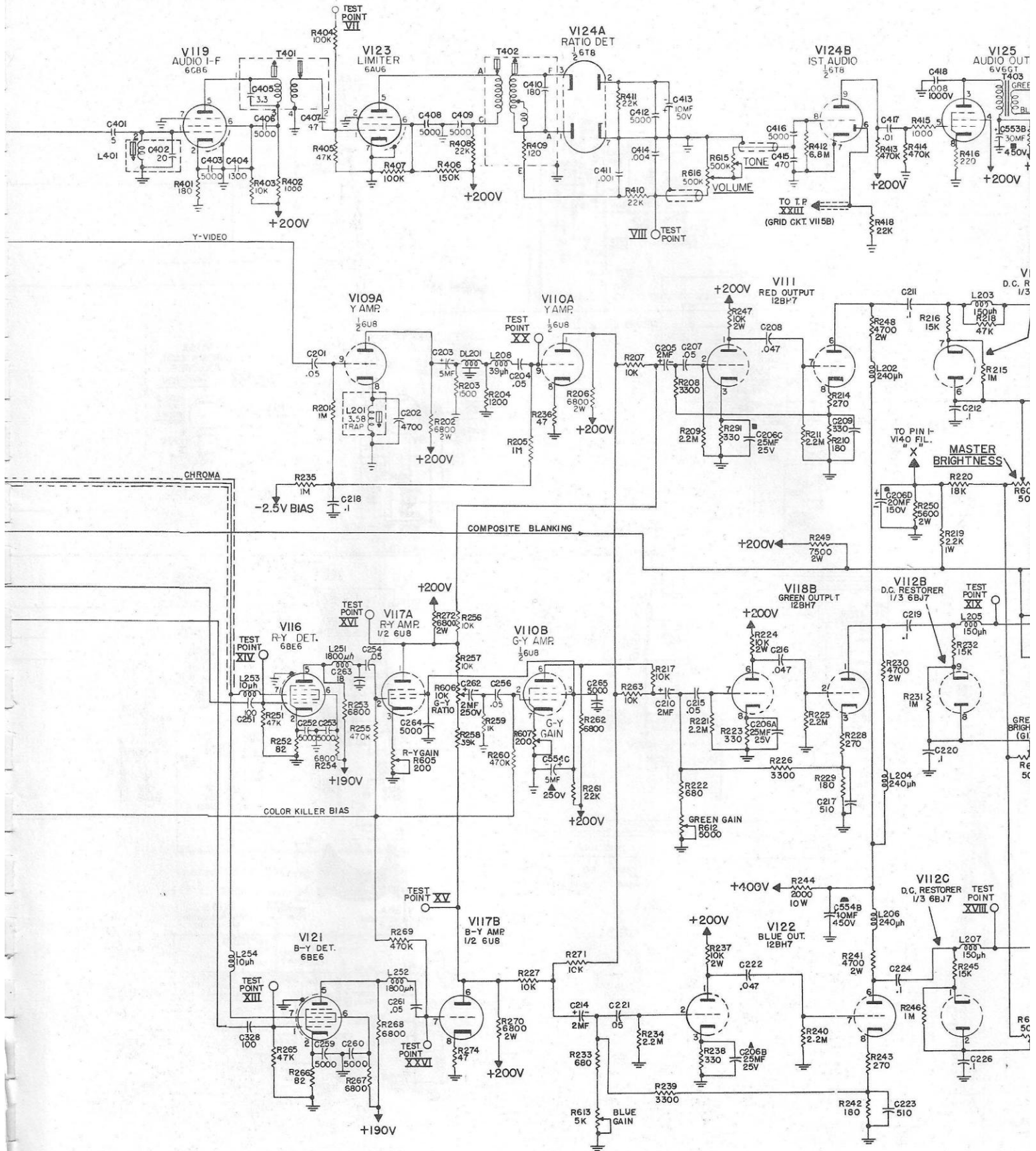

COLOR MODEL 15CL100 (First Production)

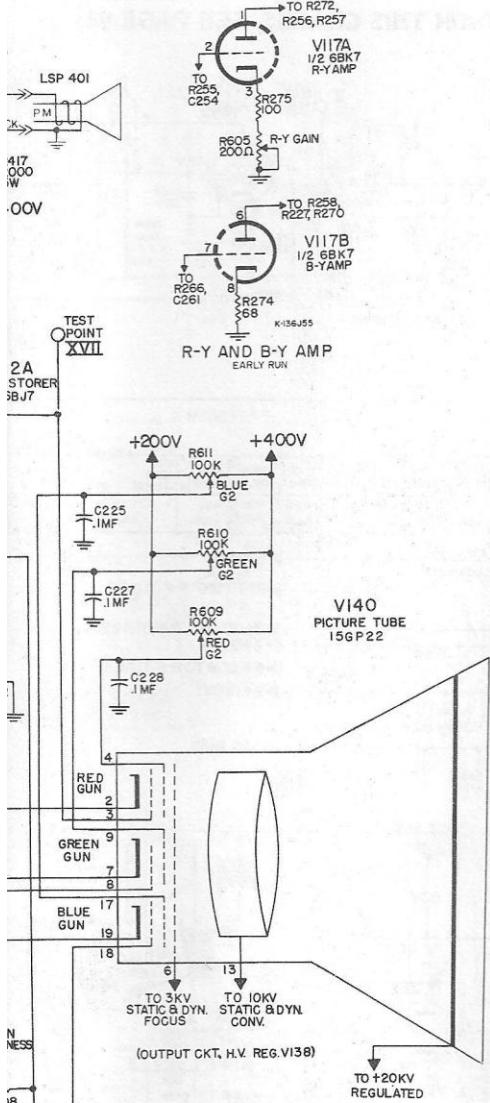

ALL CAPACITORS GREATER THAN 1 IN MMF & LESS THAN 1 IN MF EXCEPT WHERE OTHERWISE NOTED
 ALL RESISTORS 1/2 WATT EXCEPT WHERE OTHERWISE NOTED
 RESISTANCE VALUES IN OHMS
 K=1000
 M=MEG
 ALL POTENT DENOTED IN R600 SERIES

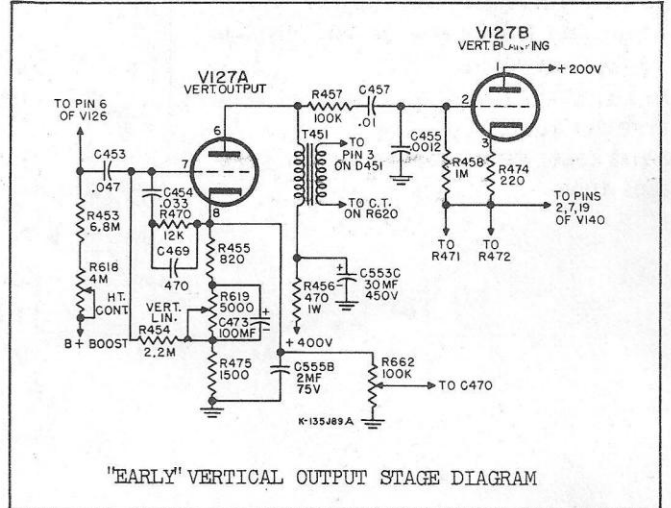
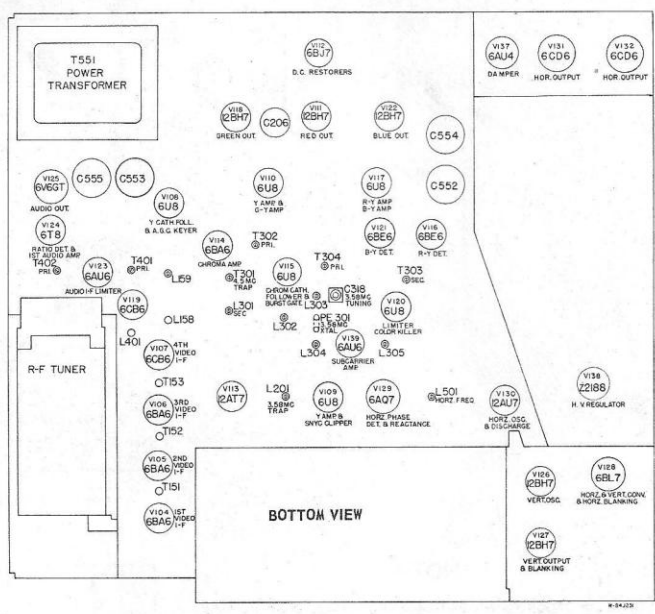
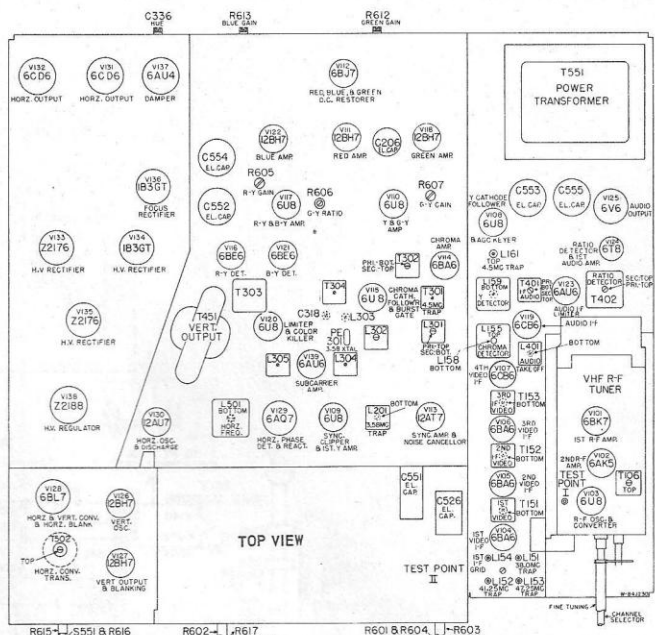

FOR TUNERS USED ON THIS CHASSIS, SEE PAGE 94.

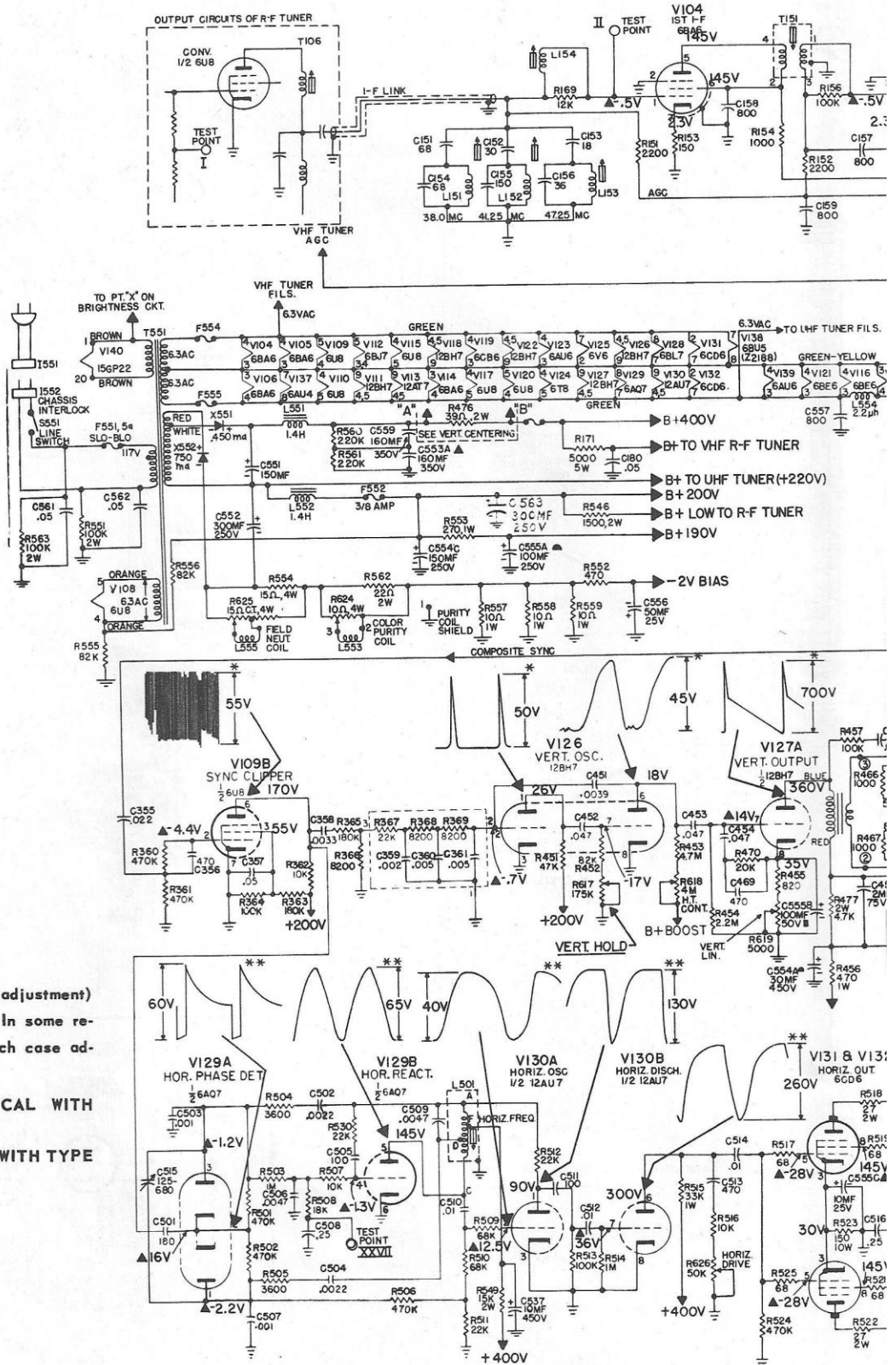

NOTE

1. Adjust R630 (high voltage regulator adjustment) for ½ volt across R541 (390 ohms). In some receivers R541 is 1000 ohms, in which case adjust for 1 volt instead.
2. Z-2176 RECTIFIER IS IDENTICAL WITH TYPE 2V2 TUBE.
Z-2188 REGULATOR IS IDENTICAL WITH TYPE 6BU5 TUBE.

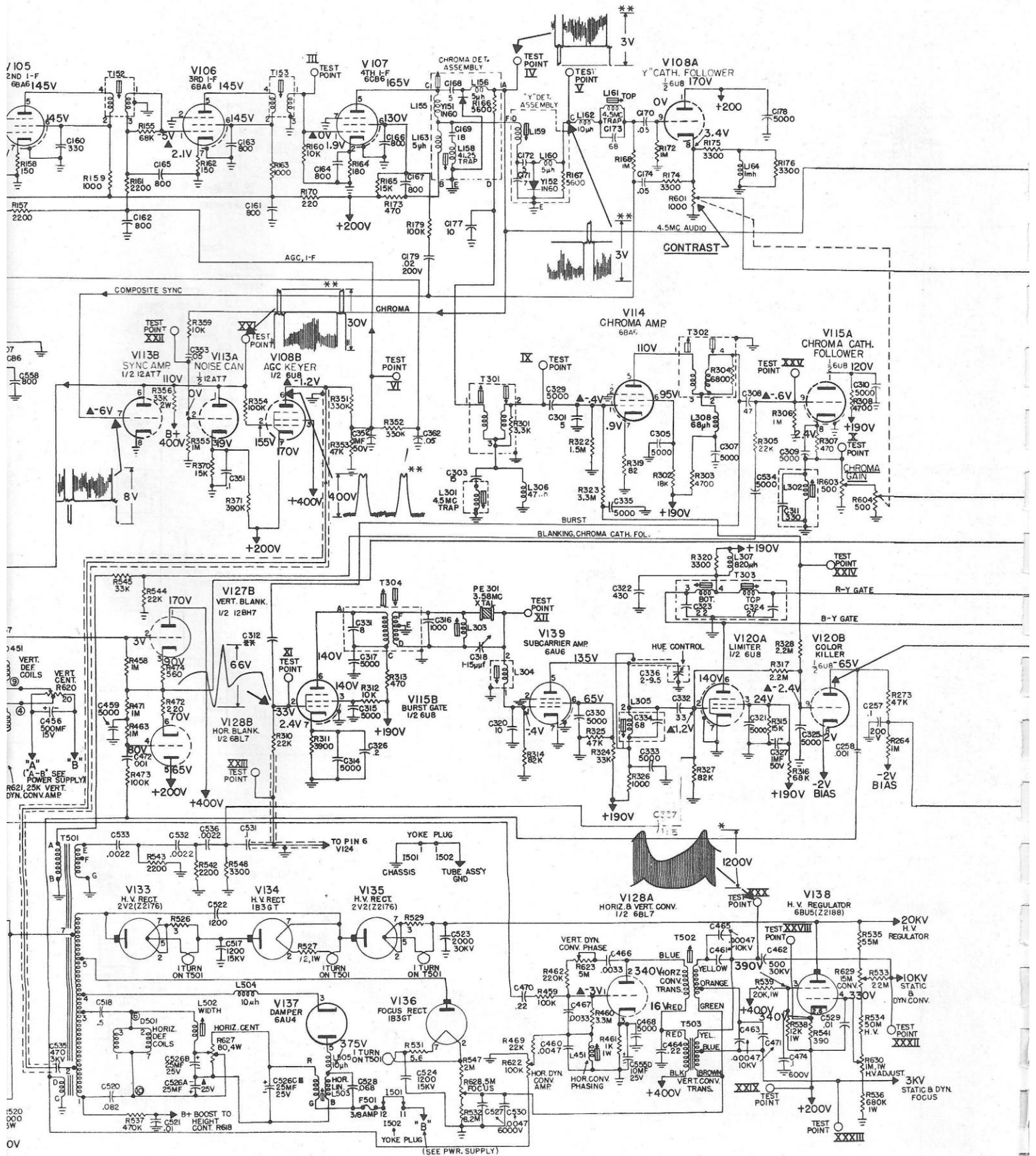

(SEE PWR. SUPPLY)

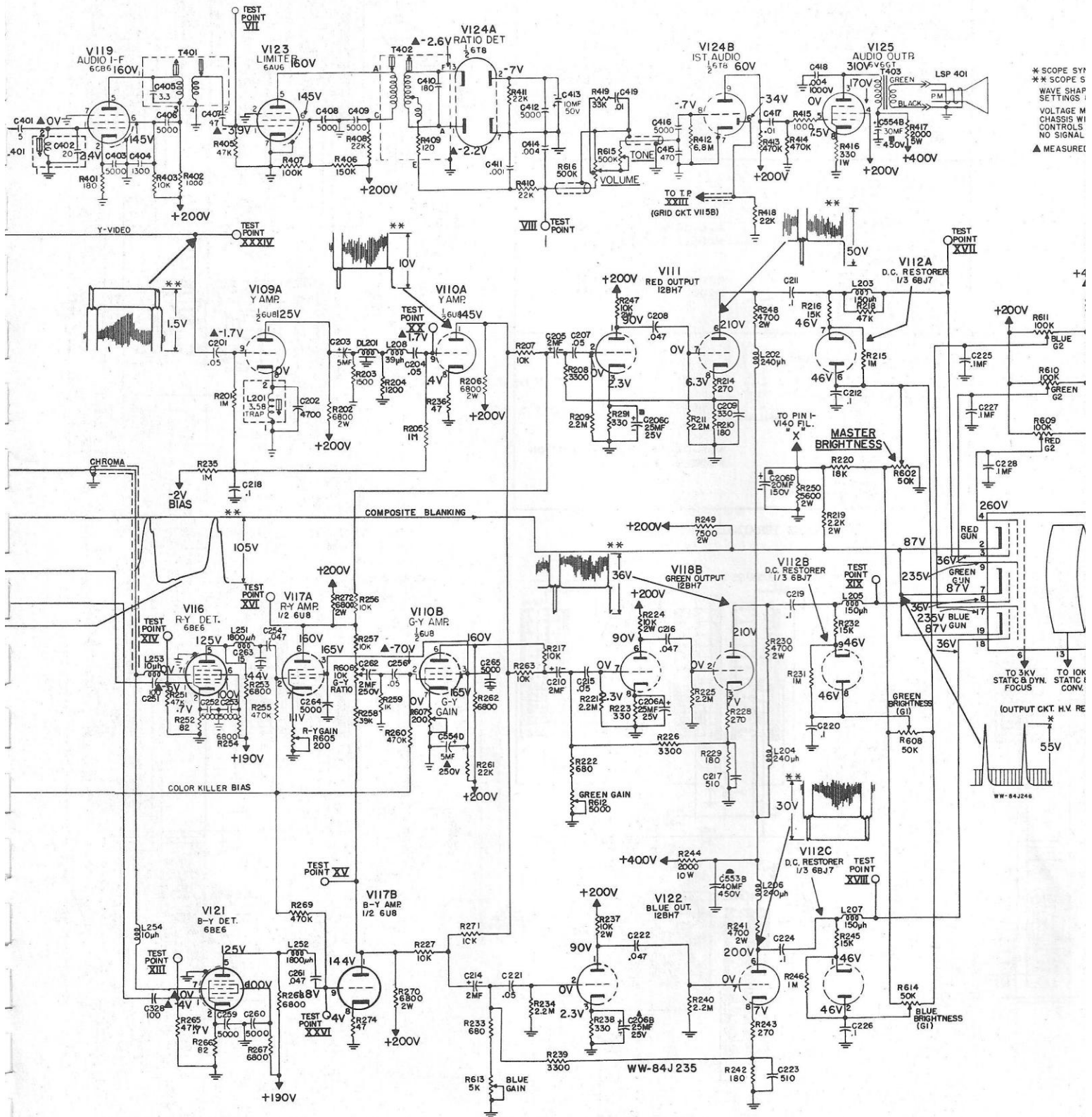

* SCOPE SY
 ** SCOPE S
 WAVE SHAP
 SETTINGS
 VOLTAGE M
 CHASSIS W
 CONTROLS
 NO SIGNAL
 ▲ MEASURE

WW-84J246

(OUTPUT CKT. H.V. RE

COLOR MODEL 15CL100 (Second Production)

MEASURED AT 1/2 VERT. FREQUENCY.
 MEASURED AT 1/2 HORIZ. FREQUENCY.
 MEASUREMENTS ARE IN RESPECT TO
 A 20,000 Ω/VOLT METER, WITH
 NORMAL SIGNAL APPLIED.

MEASUREMENTS ARE IN RESPECT TO
 A 20,000 Ω/VOLT METER, WITH
 NORMAL SIGNAL APPLIED.

WITH VTVM

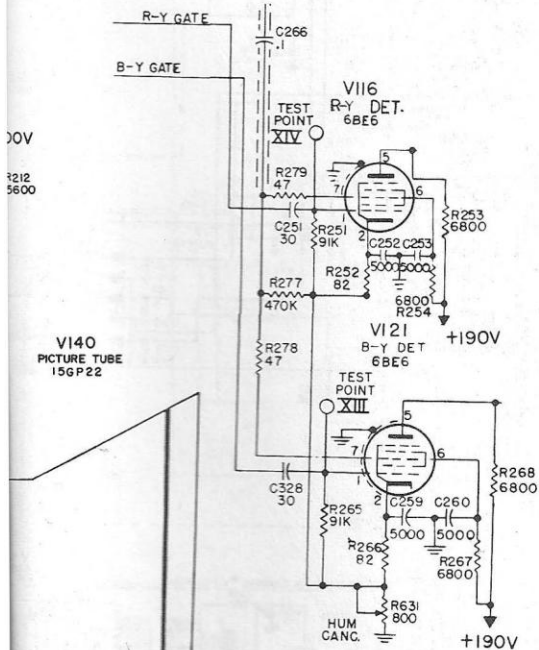

TO +20KV REGULATED

ALL CAPACITORS GREATER THAN 1 IN MMF & LESS THAN 1 IN MF EXCEPT WHERE OTHERWISE NOTED
 ALL RESISTORS 1/2 WATT EXCEPT WHERE OTHERWISE NOTED
 RESISTANCE VALUES IN OHMS
 K = 1000
 M = MEG
 ALL POTENT DENOTED IN R600 SERIES

